

## STEVAL-IHM020V1 demonstration board based on the STCC08 AC switch failure mode detector

### Introduction

The STEVAL-IHM020V1 demonstration board (see [Figure 1](#)) provides a means to evaluate the performance of the STCC08, which is an AC switch failure mode detector and an AC power switch driver. The device is dedicated to driving up to 10 mA IGT AC switches (ACS, ACST and TRIACs), and detecting any switch failures. This solution embeds a switch driver and an AC switch state detector. It contributes to system safety by monitoring AC switches driving sensitive loads such as drain pumps, door locks, heaters, cooling fans, and compressors.

**Figure 1. STEVAL-IHM020V1, STCC08 demonstration board**

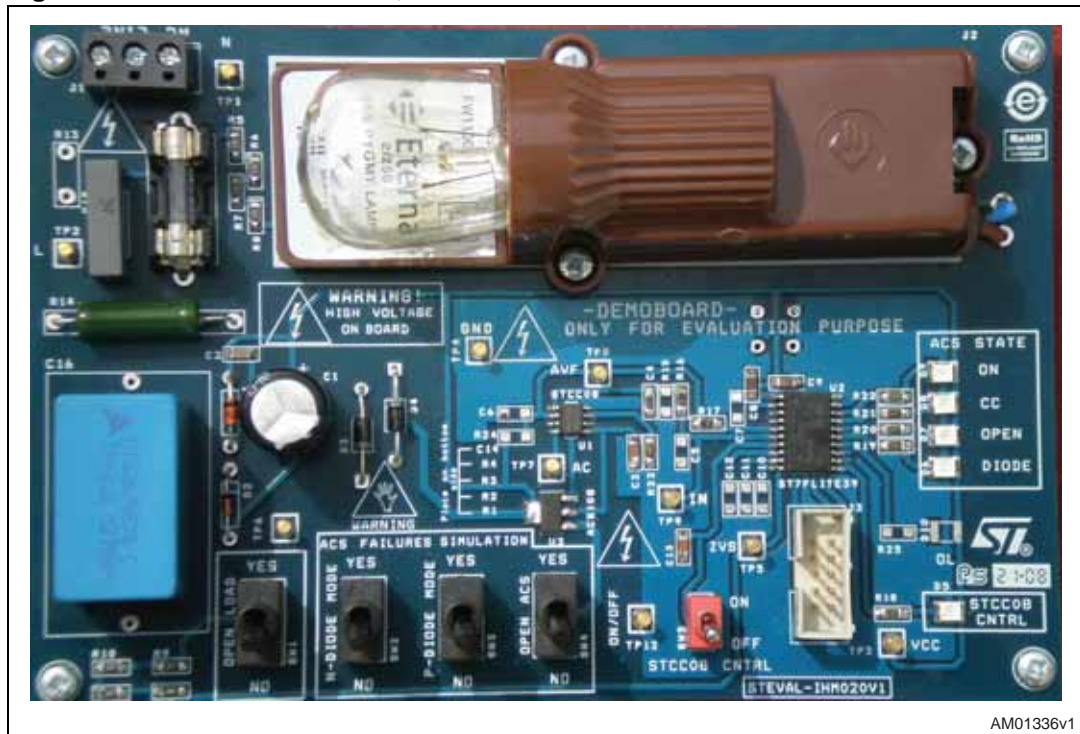

This user manual provides all information needed to set up and operate the demonstration board. With this demonstration board, you can:

- Evaluate the full ST solution (microcontroller + STCC08)
- Test and analyze the AC switch failure detection features of the STCC08 device

# Contents

- 1 Demonstration board introduction ..... 4**
  - 1.1 Package contents ..... 4
  - 1.2 Board presentation ..... 4
- 2 STCC08 description ..... 6**
  - 2.1 Block diagram description ..... 6
  - 2.2 Gate driver ..... 7
  - 2.3 ACS failure detection ..... 7
- 3 Features ..... 10**
  - 3.1 ST7LITE39F2 microcontroller ..... 10
  - 3.2 DC capacitive power supply ..... 10
- 4 Using the demonstration board ..... 12**
  - 4.1 Load ..... 12
  - 4.2 Measurement points ..... 12
  - 4.3 Getting started ..... 13
    - 4.3.1 Procedure ..... 13
- 5 IEC 61000-4-4 Burst immunity test ..... 16**
  - 5.1 Test conditions ..... 16
  - 5.2 Demonstration board immunity test ..... 16
  - 5.3 Recommendations for improving application immunity ..... 16
- 6 Conclusion ..... 18**
- Appendix A STCC08 demonstration board schematic ..... 19**
- Appendix B Bill of materials ..... 20**

## List of figures

Figure 1.	STEVAL-IHM020V1, STCC08 demonstration board	1
Figure 2.	Main components used (top view)	4
Figure 3.	Main components used (top view)	4
Figure 4.	STCC08 block diagram description	6
Figure 5.	Application diagram	6
Figure 6.	AC switch failure-detection principle	8
Figure 7.	Measurement points (top layer view)	12
Figure 8.	STCC08 demonstration board (top view)	13
Figure 9.	Short-circuit detection	15
Figure 10.	Diode mode detection	15
Figure 11.	Open circuit detection	15
Figure 12.	AVF signal detection	16
Figure 13.	STEVAL-IHM020V1 demonstration board schematic diagram	19

# 1 Demonstration board introduction

## 1.1 Package contents

The following items are supplied in this package:

- Demonstration board featuring the STCC08 AC switch failure mode detector
- DVD containing user manual, product presentation and datasheets.

## 1.2 Board presentation

Figures 2 and 3 show the board and the main components used.

Figure 2. Main components used (top view)

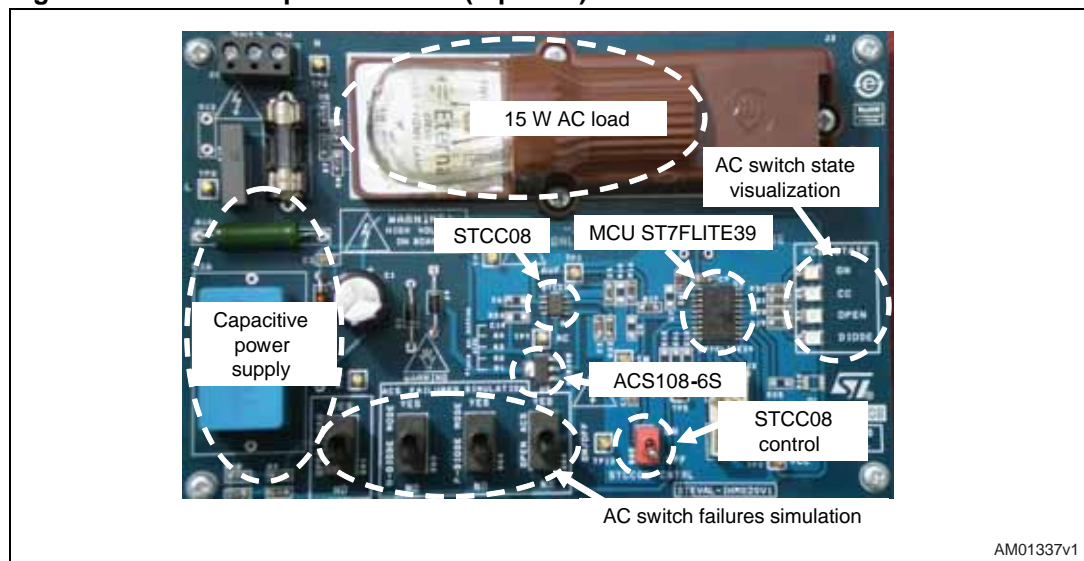

AM01337v1

Figure 3. Main components used (top view)

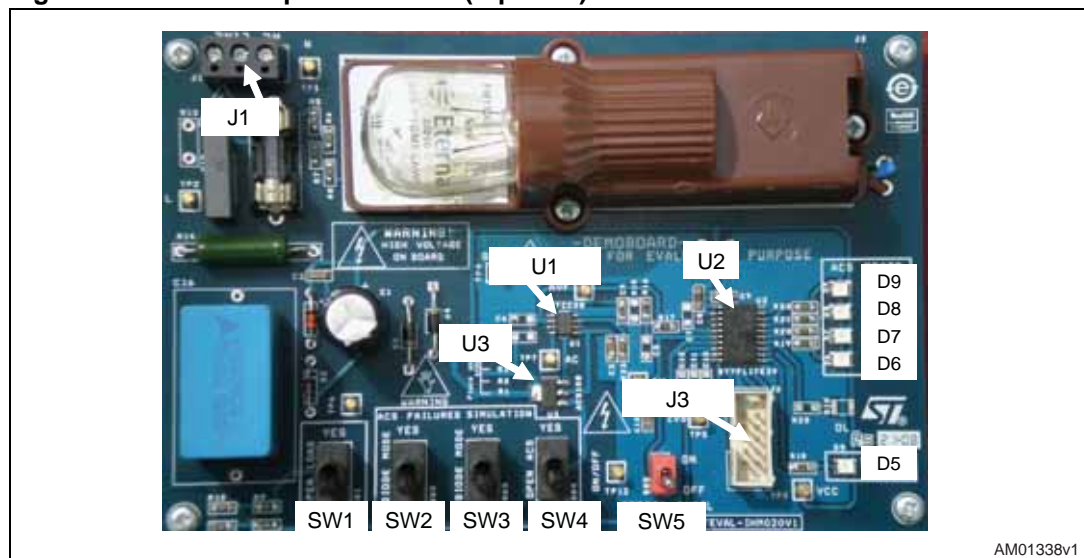

AM01338v1

Components on the demonstration board include:

- the STCC08 device (U1)
- the STLITE39F2 MCU (U2). The 8-bit MCU drives the AC switch through the STCC08, analyzes the STCC08 AVF signals and powers LEDs to indicate AC switch failures
- the ACS108-6S (U3), transient voltage protected AC switch
- A capacitive DC power supply
- An ICC (in-circuit connector) (J3) to load the firmware in the MCU.

---

**Warning:** Before the board is connected to a computer through the ICC connector, ensure that the AC line is connected to the board through an insulated plug. This is essential to avoid electrical shock.

---

- A switch to simulate an AC load failure in open circuit (SW1)
- 2 switches (SW2, SW3) to simulate a diode mode failure in both polarities of the AC line and a short-circuit of the AC switch (when SW2 and SW3 are in the “YES” position at the same time)
- A switch to simulate an AC switch failure in open circuit (SW4)
- An STCC08 CNTRL switch (SW5). This switch is used to turn the AC switch (ACS) on or off through the MCU and the STCC08
- An STCC08 CNTRL LED (D5), used to see whether or not the AC switch has been controlled by the user
- LEDs to define the ACS state
  - A “DIODE” LED (D6) to visualize an ACS failure in diode mode in both AC line cycles. The LED is on if the AC switch fails in diode mode.
  - An “OPEN” LED (D7) to indicate an ACS failure in open circuit. This LED is on if the AC switch is damaged in open circuit
  - A “CC” LED (D8) to show an ACS failure in short-circuit on both polarities of the AC line. This LED is on if the AC switch is damaged in short-circuit
  - An “ON” LED (D9) to indicate that the AC switch is on
- Test points to allow the connection of voltage probes:
  - L (TP2) and N (TP1): line and neutral of the AC line
  - VCC (TP3): positive power supply
  - GND (TP4): power supply reference
  - ZVS (TP5): zero crossing of the AC line voltage
  - OUT (TP6): anode of the ACS
  - AC (TP7): ACS status sense input
  - AVF (TP8): alternating voltage feedback. ACS status output
  - ON/OFF (TP12): “STCC08 CNTRL” switch state, used to turn on or off the ACS through the MCU and the STCC08
  - IN (TP9): STCC08 IN input used to control the ACS
- An AC line connector (J1)
- An AC load: light bulb (15 W at 230 V<sub>RMS</sub>).

For more detailed information, please refer to the schematic diagram in [Appendix A](#).

## 2 STCC08 description

### 2.1 Block diagram description

Figure 4 shows the block diagram of the STCC08. It includes a “gate driver” block to control the AC switch, a “power switch signal shaping” block used to read the AC switch state and a buffer able to send the AC switch state to the MCU (AVF DRIVER). This signal should be analyzed by the MCU, which can power-off the application in hazardous situations (for example, to open a relay (SW) placed in the front-end of the application - see Figure 5). Table 1 provides the pin definitions of the STCC08.

Figure 4. STCC08 block diagram description

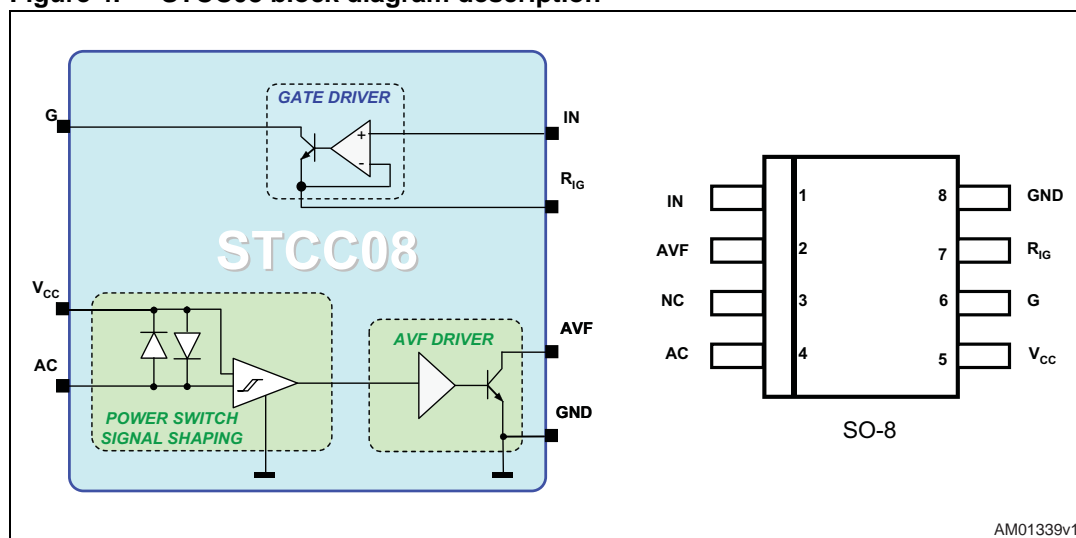
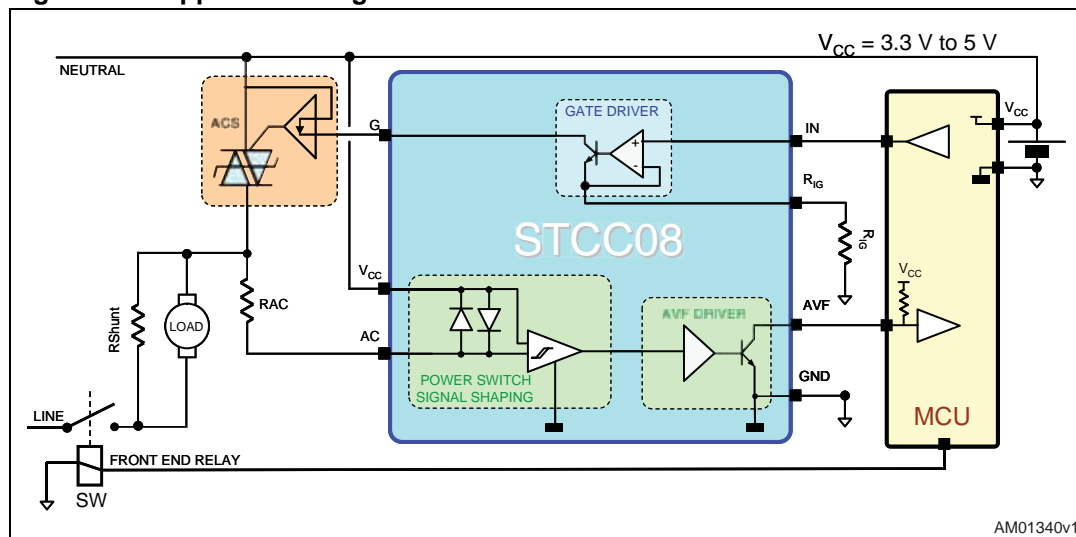

Figure 5. Application diagram



Note: The STCC08 AVF driver block is used to send the AC switch state to the MCU. The AVF output is an open collector and should be loaded with an external resistor or connected directly to the MCU, in pull-up input configuration.

Table 1. STCC08 pin definition

Pin	Symbol	Type	Description
1	IN	Signal	AC switch drive
2	AVF	Signal	Alternating voltage feedback: AC switch state output
3	NC		Not connected
4	AC	Signal	AC switch state sense input
5	VCC	Power	Positive power supply
6	G	Signal	AC switch gate driver output
7	RIG	Signal	AC switch gate current setting
8	GND	Power	Power supply reference

## 2.2 Gate driver

The STCC08 can control up to 10mA IGT TRIACs, ACST and ACS through a “GATE DRIVER” block designed:

- to drive the AC switch according to the IN control input state:
  - For IN = “1” = VCC: AC switch turn on
  - For IN = “0” = GND: AC switch turn off
- to regulate the gate current of the AC switch, thanks to the internal current controller

## 2.3 ACS failure detection

External resistors (R1, R2, R3 and R4) sense the voltage across the ACS. Using these resistors, the STCC08 constantly monitors the ACS state. Knowing the STCC08 IN input state, the ACS state can be deduced by analyzing the AVF signal. [Figure 6](#) gives the ACS state according to the AVF signal state and the IN signal state.

Figure 6. AC switch failure-detection principle

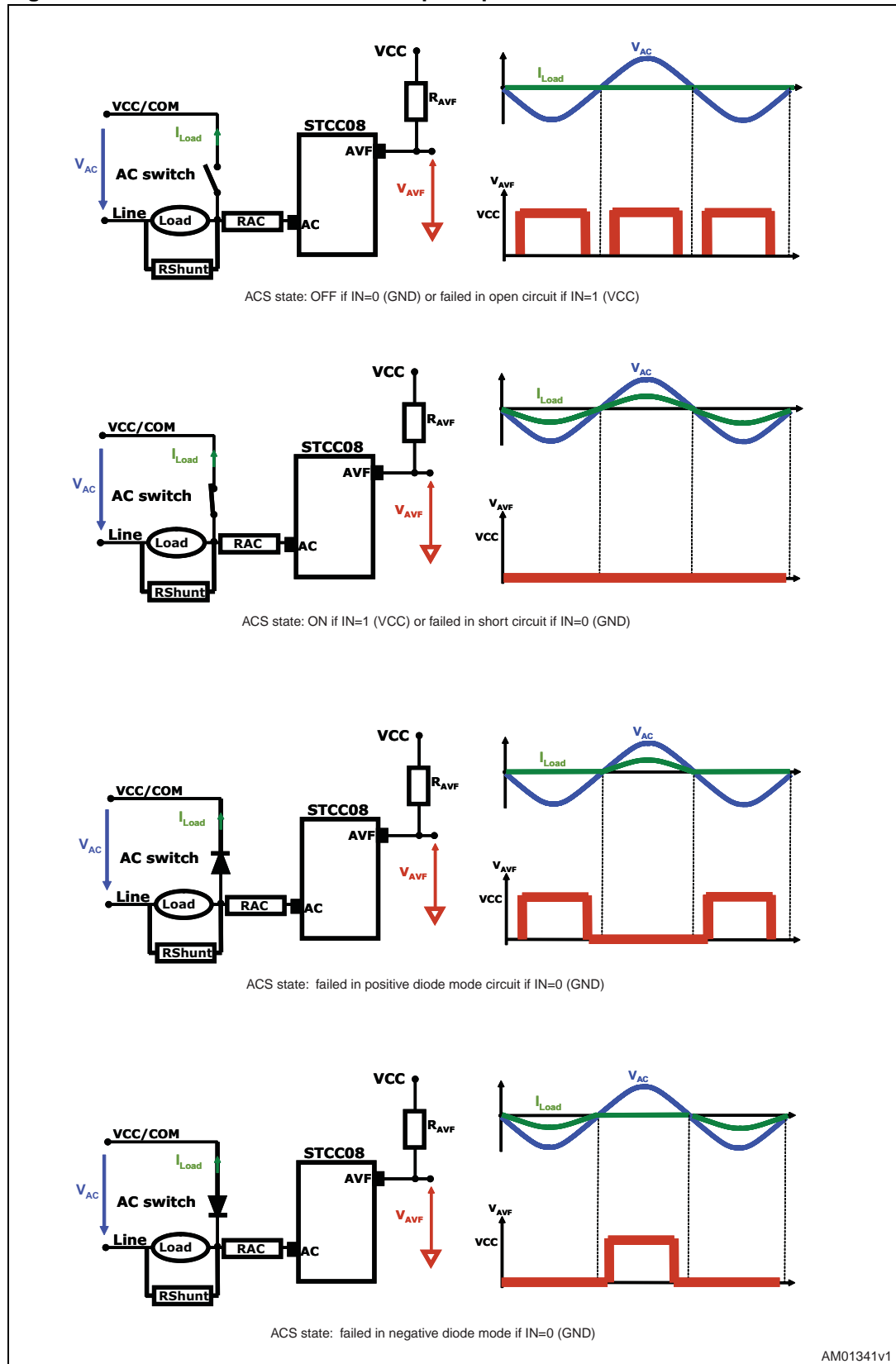



*Table 2* gives the AC switch state according to the AVF signal and the MCU control (IN). Knowing the IN signal state, the MCU is able to define the AC switch state by analyzing the AVF signal. According to the failure mode, the MCU can place the system in a safe configuration by switching off the home appliance front-end relay.

**Table 2. AVF output definition**

STCC08 control (IN)	AVF signal	AC switch states
0	+V <sub>CC</sub> (except at each zero crossing of the AC line)	OFF (no failure)
0	Toggle from +V <sub>CC</sub> to 0	Diode mode
0	0	Short-circuit
1	0	ON (no failure)
1	+V <sub>CC</sub> (except at each zero crossing of the AC line)	Open circuit

*Note:* "If the AC switch is damaged in short-circuit: the 'CC' LED is ON (D8)"

"f the AC switch is damaged only in one direction (diode mode): the 'DIODE' LED is ON (D6)"

## 3 Features

### 3.1 ST7LITE39F2 microcontroller

The 8-bit MCU used in this board is the ST7LITE39F2. It belongs to the ST7 family of microcontrollers, and offers a large number of features at minimum cost.

- The peripheral hardware requirements are reduced to a minimum:
  - No quartz or external resonator is used. Instead, an internal RC-oscillator in the ST7LITE3 is used to generate the clock
  - No external RESET circuit is used
- In the MCU firmware, four options must be set:
  - Software watchdog activation
  - RC oscillator selection
  - PLL disabled
  - Low voltage detection selection

*Note:* The MCU firmware has been developed only to evaluate the STCC08 device and is not compliant with the class B (IEC60335-1 Ed4) requirements.

### 3.2 DC capacitive power supply

A DC capacitive power supply is used on the board. One peculiarity of this DC power supply is that it is “negative”. The  $V_{CC}$  terminal is connected to neutral. This means that the GND voltage is 5 V below neutral. Such a connection is mandatory to drive the ACS. Indeed, the ACS can only be triggered by a negative current (i.e. sourced from the gate). The maximum average current absorbed by the board is about 44 mA (see [Table 3](#)). In this case, a 2.2  $\mu\text{F}$  C16 capacitor value has been used to ensure that the board works correctly in the worst application conditions (230 V/110  $V_{RMS}$  line voltage  $\pm 10\%$  and  $V_{CC} \pm 10\%$ ).

**Table 3. Maximum average current sunk by the board**

Device	Average current consumption	Comments
MCU	2.5 mA	Maximum supply current in run mode. $F_{CPU}=1$ MHz and $V_{CC}=5.5$ V
LEDs (two LEDs maximum can be ON at the same time)	15 mA	LED STCC08 controlled LEDs visualizing the ACS failure $R_{19}=R_{20}= R_{21}= R_{22}=475 \Omega \pm 1\%$
Maximum current consumed by STCC08 (include the gate current of the ACS)	26 mA	$V_{CC\_MAX}=5.5$ V, temperature = 0° C $R_{IG} = 43.2 \pm 1\%$ (R23)
Others (mechanical switch)	0.5 mA	$V_{CC\_Max}=5.5$ V
Total	44 mA	

Note that a 43.2  $\Omega$   $R_{IG}$  resistor (R23) value is used. In this case, the minimum ambient temperature must be 0 °C in order to work correctly the board. For lower ambient

temperatures, please refer to application note AN2716 to redefine the  $R_{IG}$  resistor, and STCC08 consumption to redefine the C16 capacitor value.

To reduce the surge current when the board is powered, a  $39\ \Omega$  R14 resistor is connected in series with the C16 capacitor. Moreover, note that for  $110\ V_{RMS}$  AC line voltage, the  $V_{CC}$  decreases (3.8 V), but the STCC08 demonstration board remains completely functional.

The minimum power supplied to the STCC08 must be higher than 3.3 V.

## 4 Using the demonstration board

### 4.1 Load

The ACS included in the board can withstand a 0.8 A RMS permanent current up to an ambient temperature of 80 °C. The switch can drive common washing-machine AC loads without difficulty. In this demonstration board, a light bulb is used to simulate an AC load.

### 4.2 Measurement points

Figure 7 shows where the test points are located on the board. Table 4 gives the measurement point definitions.

Figure 7. Measurement points (top layer view)

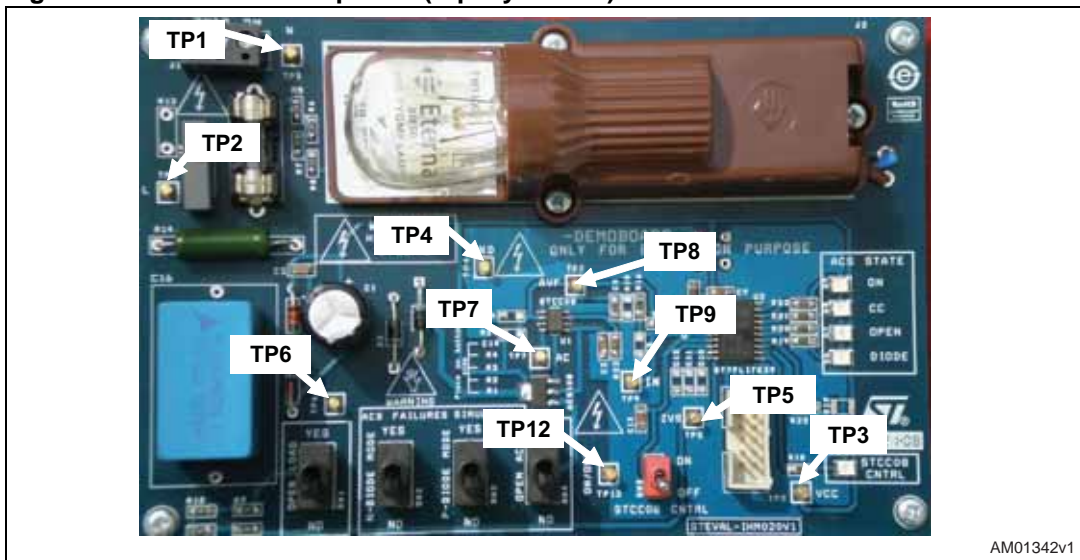

Table 4. Measurement points

Footprint name	Description
L (TP2)	Line
N (TP1)	Neutral
OUT (TP6)	Anode of the ACS
VCC (TP3)	DC power supply (also connected to ACS cathodes)
GND (TP4)	GND power supply
ON/OFF (TP12)	STCC08 control status
ZVS (TP5)	Zero voltage signal at MCU input
AVF (TP8)	ACS status output connected to MCU input
AC (TP7)	AC switch status sense input
IN (TP9)	STCC08 input driving the ACS

### 4.3 Getting started

**Warning:** The demonstration board is not electrically isolated from the AC input. The MCU is directly linked to the mains voltage. No insulation is ensured between the accessible parts and the high voltage. The STCC08 demonstration board must be used with care and only by persons qualified to work with electricity at mains voltage levels.

Any measurement equipment must be isolated from the mains before powering the board. To use an oscilloscope with the demonstration board, it is safer to isolate it from the AC line. This prevents electric shocks which can occur as a result of touching any single point in the circuit, but does not prevent shocks when touching two or more points in the circuit.

There is no insulation varnish on solder points. Care should be taken when performing measurements (for example, voltage probes must be connected only when the line and the power supply voltages are removed).

#### 4.3.1 Procedure

Figure 8 shows the board and the main components used.

Figure 8. STCC08 demonstration board (top view)

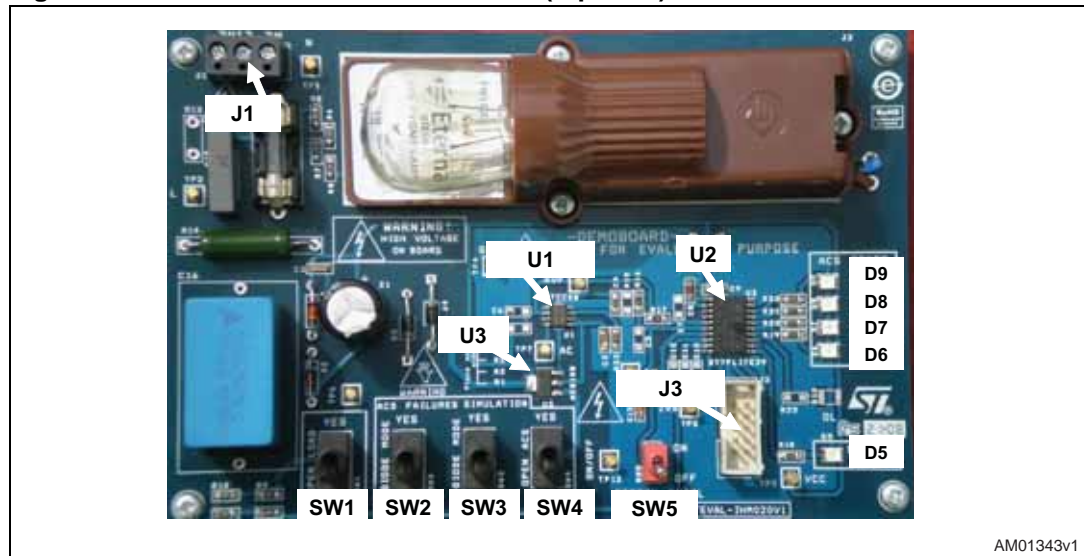

AM01343v1

- To operate the STCC08 board correctly and at each test, perform the following procedure first:
  - Place the “STCC08 CNTRL” switch (SW5) to the “OFF” position
  - Set the “N DIODE MODE (SW2)” and “P DIODE MODE (SW3)” switches to the “NO” position
  - Put the “OPEN LOAD” (SW1) switch in the “NO” position
  - Set the “OPEN ACS” (SW4) switch to the “NO” position
  - Connect the AC mains wire to the AC line connector (J1).
  - In this case, all LEDs must be off
- To turn on the AC switch:
  - Place all mechanical switches (SW1, SW2, SW3 and SW4) in the “NO” position
  - Put the “STCC08 CNTRL” switch (SW5) in the “ON” position
  - The “STCC08 CNTRL” LED (D5) and the “ON” LED (D9) must be on
  - The light bulb must be on
- To simulate a diode mode of the ACS:
  - Set the “N DIODE MODE” (SW2) or “P DIODE MODE” (SW3) switch to the “YES” position, SW1 and SW4 to the “NO” position and SW5 to the “OFF” position
  - In this case, the “DIODE” (D6) LED is on
- To simulate a short-circuit of the ACS:
  - Put the “N DIODE MODE” (SW2) and “P DIODE MODE” (SW3) switches in the “YES” position, SW1 and SW4 in the “NO” position and SW5 in the “OFF” position
  - In this case, the “CC” LED (D8) is on
- To simulate an open circuit of the ACS:
  - Place the “STCC08 CNTRL” switch (SW5) in the “ON” position and all mechanical switches (SW1, SW2, SW3 and SW4) in the “NO” position
  - Put the “OPEN ACS” (SW4) switch in the “ON” position
  - In this case, the “OPEN” LED (D7) and “STCC08 CNTRL” LED (D9) is on
- To simulate AC switch failures in any AC load state:
  - Place the “OPEN LOAD” (SW1) switch in the “YES” position (this disconnects the AC load) and use the previous procedures to see the AC switch (ACS) state is detected whatever the AC load state (AC load connected or disconnected)
- Read the “AVF” test point (TP8) with an oscilloscope connected through an insulated plug (see example in [Figure 9](#), [10](#) and [11](#)).

Figure 9. Short-circuit detection

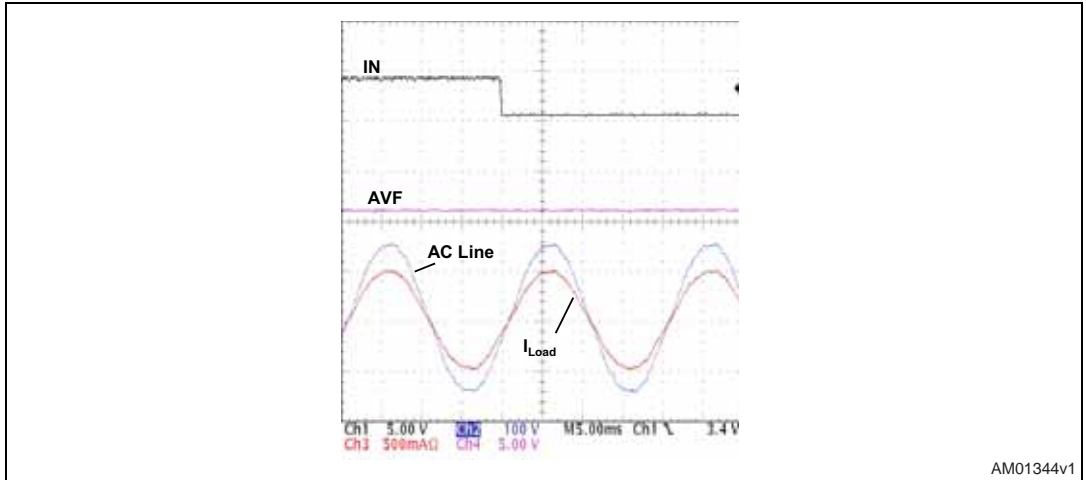

AM01344v1

Figure 10. Diode mode detection

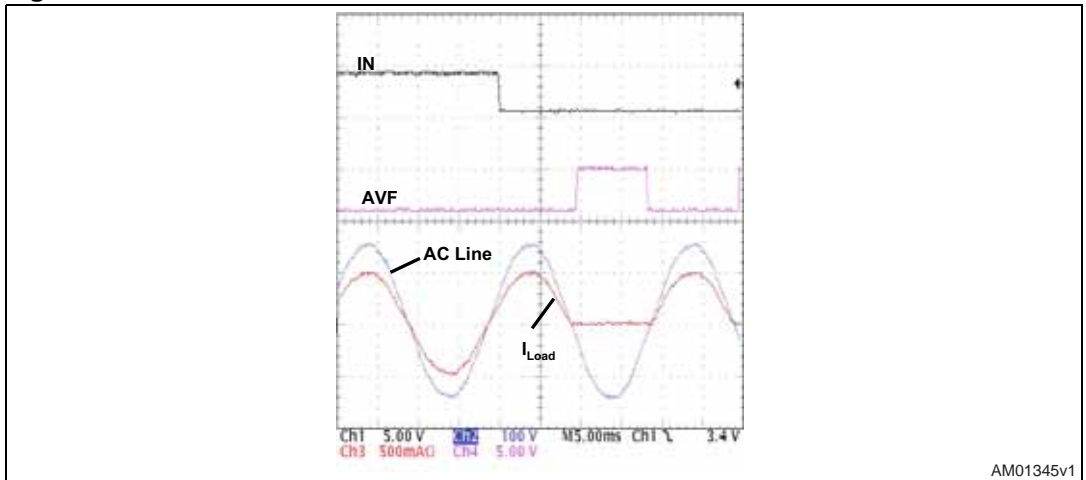

AM01345v1

Figure 11. Open circuit detection

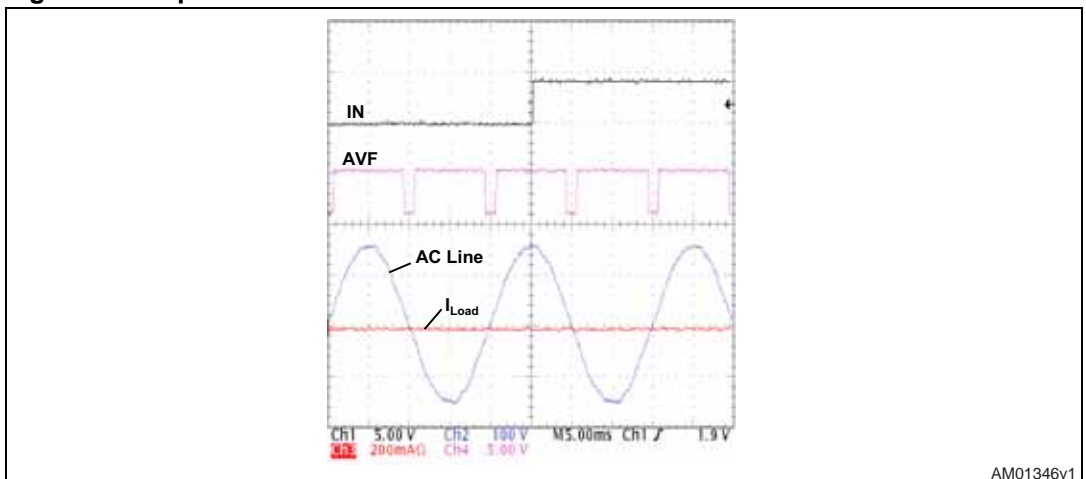

AM01346v1

## 5 IEC 61000-4-4 Burst immunity test

### 5.1 Test conditions

- Ambient temperature: 25 °C
- Relative humidity: 35%
- Test performed in accordance with IEC 61000-4-4

### 5.2 Demonstration board immunity test

The AC line input X2 capacitor C15 (10 nF) is used to help avoid triggering the AC switch (ACS108-6S). The MCU program reads the AVF signal at each AC line peak voltage (see [Figure 12](#)). The AC switch state detection is deducted if the AVF signal remains at the same level for three consecutive AC line cycles.

Figure 12. AVF signal detection

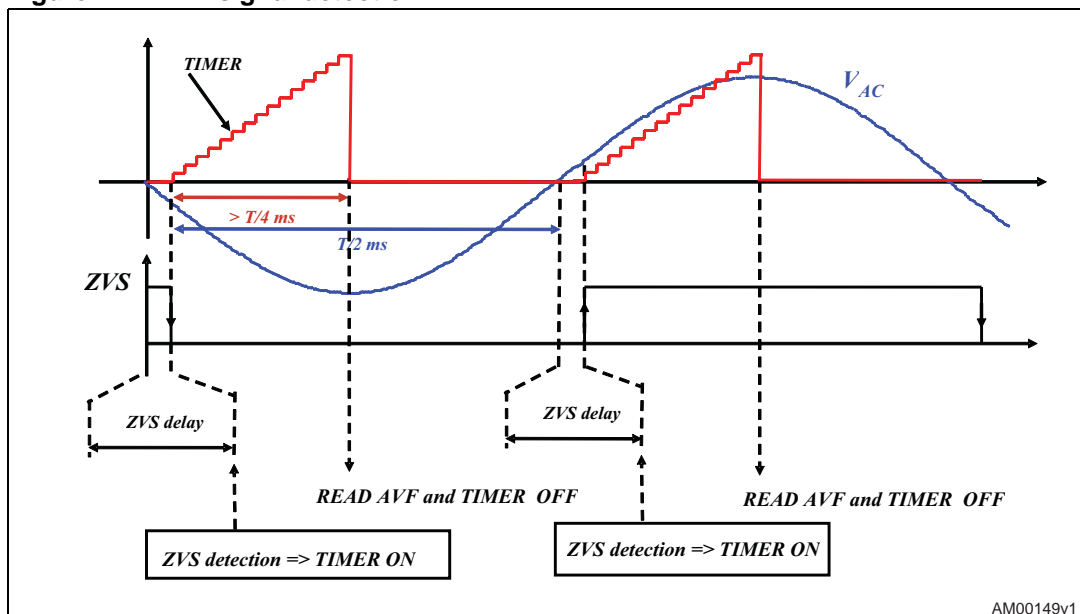

The demonstration board and mains wires are placed 10 cm above the ground reference. The mains wire is shorter than 1 m. Each operating cycle has been tested (load OFF and ON). The burst withstanding level is higher than 4 kV without spurious triggering of the ACS or ST7Lite3 MCU loss, whatever the coupling mode (to L, N, PE, etc.).

### 5.3 Recommendations for improving application immunity

To improve application EMC performance, the software must be EMC-oriented (for more information please refer application note AN1015):

- Auto-recovery routine. At each RESET interrupt, the program must check if the data in the RAM are stored as scheduled. Indeed, a RESET can occur without the supply voltage having fallen below  $V_{RM}$  (data retention parameter). In this case, a complete startup is not necessary, and the program can continue working with the previous RAM



data. This maintains the previous switch state, for example, when a RESET occurs due to an EMI problem. If, when checked, the RAM registers are not as expected, a complete initialization procedure is launched. If the RAM area is adequate, then a “smart reset” can be performed. Only the registers which are used to store internal sub-routine variables are cleared, and only the main registers keep their previous values (AC switch status, AC switch control, etc)

- Use the watchdog properly. Enable the watchdog as soon as possible after reset and never refresh the watchdog in an interrupt routine
- Secure the unused program memory area. Fill the unused memory locations with code that forces a watchdog reset or jumps to a known program location if you do not want to generate a reset
- Input filtering. Its recommended to read the AVF signal during several AC line cycles.

## 6 Conclusion

The STEVAL-IHM020V1 demonstration board has been developed to:

- Demonstrate the STCC08 failure-detection capabilities
- Show how to connect the STCC08 to an MCU (non-insulated version)
- Give the user the opportunity to evaluate a full ST solution (microcontroller + STCC08).

This user manual is intended to help home appliance designers test and evaluate the STCC08 AC switch failure mode detector using the demonstration board.

# Appendix A STCC08 demonstration board schematic

Figure 13. STEVAL-IHM020V1 demonstration board schematic diagram

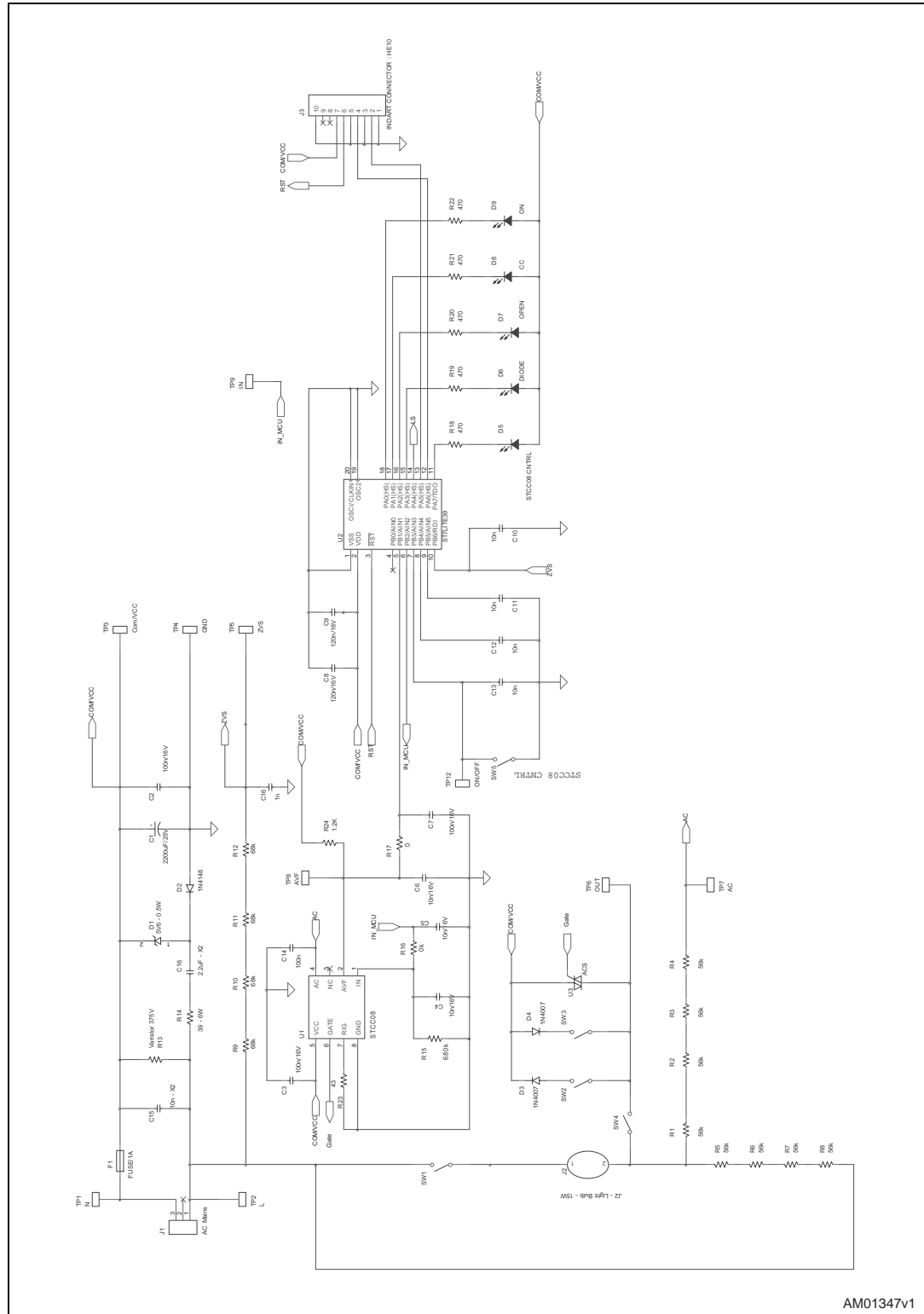

AM01347v1

## Appendix B Bill of materials

**Table 5. Bill of material**

Ref.	Part/value	Tolerance (%)	Voltage/current	Watts	Technology information	Package footprint
U1	STCC08					SO-8
U2	ST7LITE39FM6					SO-20
U3	ACS108-6S					SOT 223
R1, R2, R3, R4, R5, R6, R7, R8	56 kΩ	5		1/4 W		SMD 1206
R9, R10, R11, R12	68 kΩ	5		1/4 W		SMD 1206
R14	39 Ω	5	> 700 V	6 W		Through-hole
R15	680 kΩ	5		1/4 W		SMD 1206
R16, R17	0 Ω	5		1/4 W		SMD 1206
R18, R19, R20, R21, R22	475 Ω	5		1/4 W		SMD 1206
R23	43.2 Ω	1		0.125 W		SMD 1206
C1	2200 μF	20	16 V		Radial electrolytic	
C2, C3	100 nF	20	50 V			SMD 1206
C8, C9	120 nF	20				SMD 1206
C13	10 nF	20	50 V			SMD 1206
C15	10 nF	20	300 V c.a.		X2	Through-hole - pitch: 15 mm
C16	2.2 μF	20	400 V		X2	Through-hole - pitch 27.5 mm
D1	Zener diode 5V6		5V6	0.5 W		Through-hole - DO41
D2	Rectifier 1N4148					Through-hole
D3, D4	Rectifier 1N4007					Through-hole
D5, D9	GREEN LED - CMS					CMS TOPLED
D6, D7, D8	RED LED - CMS					CMS TOPLED
J1	Female connector 3 inputs					Pitch: 5,08 mm

Table 5. Bill of material (continued)

Ref.	Part/value	Tolerance (%)	Voltage/current	Watts	Technology information	Package footprint
J2	LIGHT BULB - 15 W at 230 V <sub>RMS</sub>			15 W		
J3	Female connector HE10 - 2x5					
F1	Fuse		250 V/ 1 A			
SW1, SW2, SW3, SW4	Switch		250 V			
SW5	Switch		60 V			
TP1, TP2, TP3, TP4, TP5, TP6, TP7, TP8, TP9, TP12	Test point					DRILL 1.4 mm

## Revision history

**Table 6. Document revision history**

Date	Revision	Changes
12-Nov-2008	1	Initial release

**Please Read Carefully:**

Information in this document is provided solely in connection with ST products. STMicroelectronics NV and its subsidiaries ("ST") reserve the right to make changes, corrections, modifications or improvements, to this document, and the products and services described herein at any time, without notice.

All ST products are sold pursuant to ST's terms and conditions of sale.

Purchasers are solely responsible for the choice, selection and use of the ST products and services described herein, and ST assumes no liability whatsoever relating to the choice, selection or use of the ST products and services described herein.

No license, express or implied, by estoppel or otherwise, to any intellectual property rights is granted under this document. If any part of this document refers to any third party products or services it shall not be deemed a license grant by ST for the use of such third party products or services, or any intellectual property contained therein or considered as a warranty covering the use in any manner whatsoever of such third party products or services or any intellectual property contained therein.

**UNLESS OTHERWISE SET FORTH IN ST'S TERMS AND CONDITIONS OF SALE ST DISCLAIMS ANY EXPRESS OR IMPLIED WARRANTY WITH RESPECT TO THE USE AND/OR SALE OF ST PRODUCTS INCLUDING WITHOUT LIMITATION IMPLIED WARRANTIES OF MERCHANTABILITY, FITNESS FOR A PARTICULAR PURPOSE (AND THEIR EQUIVALENTS UNDER THE LAWS OF ANY JURISDICTION), OR INFRINGEMENT OF ANY PATENT, COPYRIGHT OR OTHER INTELLECTUAL PROPERTY RIGHT.**

**UNLESS EXPRESSLY APPROVED IN WRITING BY AN AUTHORIZED ST REPRESENTATIVE, ST PRODUCTS ARE NOT RECOMMENDED, AUTHORIZED OR WARRANTED FOR USE IN MILITARY, AIR CRAFT, SPACE, LIFE SAVING, OR LIFE SUSTAINING APPLICATIONS, NOR IN PRODUCTS OR SYSTEMS WHERE FAILURE OR MALFUNCTION MAY RESULT IN PERSONAL INJURY, DEATH, OR SEVERE PROPERTY OR ENVIRONMENTAL DAMAGE. ST PRODUCTS WHICH ARE NOT SPECIFIED AS "AUTOMOTIVE GRADE" MAY ONLY BE USED IN AUTOMOTIVE APPLICATIONS AT USER'S OWN RISK.**

Resale of ST products with provisions different from the statements and/or technical features set forth in this document shall immediately void any warranty granted by ST for the ST product or service described herein and shall not create or extend in any manner whatsoever, any liability of ST.

ST and the ST logo are trademarks or registered trademarks of ST in various countries.

Information in this document supersedes and replaces all information previously supplied.

The ST logo is a registered trademark of STMicroelectronics. All other names are the property of their respective owners.

© 2008 STMicroelectronics - All rights reserved

STMicroelectronics group of companies

Australia - Belgium - Brazil - Canada - China - Czech Republic - Finland - France - Germany - Hong Kong - India - Israel - Italy - Japan - Malaysia - Malta - Morocco - Singapore - Spain - Sweden - Switzerland - United Kingdom - United States of America

[www.st.com](http://www.st.com)

