

## 0.3A/0.6A Half-Bridge Gate Driver

### General Description

The RT7020 is a high-voltage gate driver IC with dual outputs. The IC, together with an external bootstrap network, drives dual N-MOSFETs or IGBTs in a half-bridge configuration with input voltage rail up to 600V.

The IC is equipped with a "common-mode dV/dt noise canceling technique" to provide high dV/dt immunity which enables stable operation under high dV/dt noise circumstances. Two Under-Voltage Lockout (UVLO) functions continuously monitor the bias voltages on VCC and BOOT-to-LX for preventing malfunction when the bias voltages are lower than the specified threshold voltages. A dead time control prevents shoot-through of the external power MOSFETs. The logic level of the PWM signal input pins are compatible with standard TTL logic level for ease of interfacing with controlling devices.

### Applications

- PDP Scan Driver
- Fluorescent Lamp Ballast
- SMPS
- Motor Driver

### Features

- Floating Channel Designed for Bootstrap Operation with Input Voltage up to 600V
- 300mA/600mA Sourcing/Sinking Current
- High dV/dt Immunity :  $\pm 50\text{V/ns}$
- VCC and VBOOT - LX Supply Range from 10V to 20V
- Under-Voltage Lockout Functions for Both Channels
- Matched Propagation Delays Between Both Channels
- TTL Compatible Logic Input
- Internal Dead-Time Setting
- High-Side Output In-Phase with HIN Input Signal
- Low-Side Output Out of Phase with LIN Input Signal
- RoHS Compliant and Halogen Free

### Ordering Information

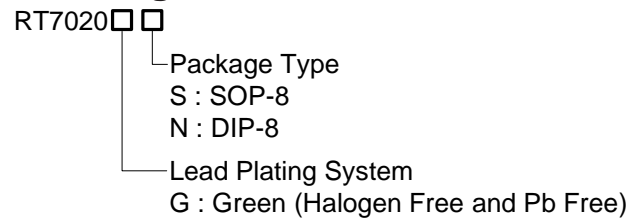

Note :

Richtek products are :

- ▶ RoHS compliant and compatible with the current requirements of IPC/JEDEC J-STD-020.
- ▶ Suitable for use in SnPb or Pb-free soldering processes.

### Simplified Application Circuit

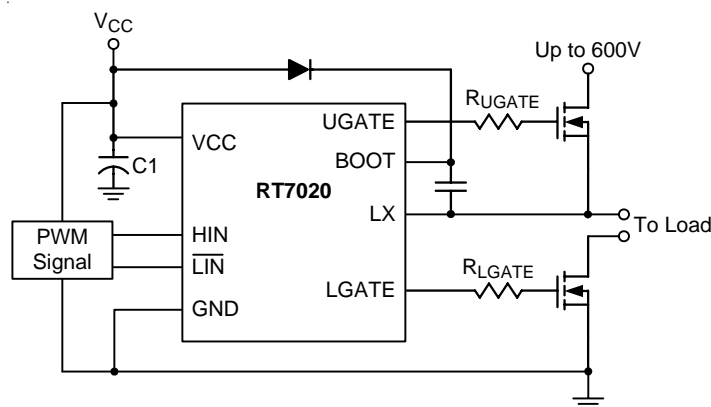

## Marking Information

RT7020GS

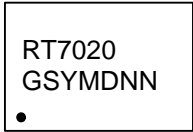

RT7020GS : Product Number  
YMDNN : Date Code

RT7020GN

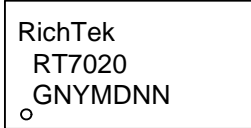

RT7020GN : Product Number  
YMDNN : Date Code

## Pin Configurations

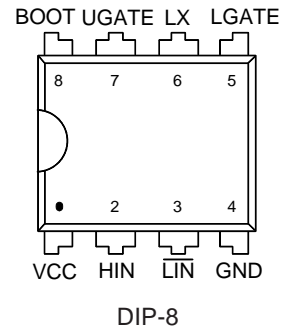
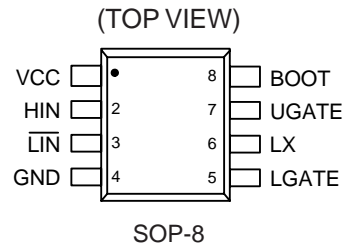

## Functional Pin Description

Pin No.		Pin Name	Pin Function
SOP-8	DIP-8		
1	1	VCC	Supply Voltage Input.
2	2	HIN	Logic Input for High-Side Gate Driver.
3	3	$\overline{\text{LIN}}$	Logic Input for Low-Side Gate Driver.
4	4	GND	Logic Ground and Low-Side Driver Return.
5	5	LGATE	Low-Side Driver Output.
6	6	LX	Return for High-Side Gate Driver.
7	7	UGATE	High-Side Driver Output.
8	8	BOOT	Bootstrap Supply for High-Side Gate Driver.

Function Block Diagram

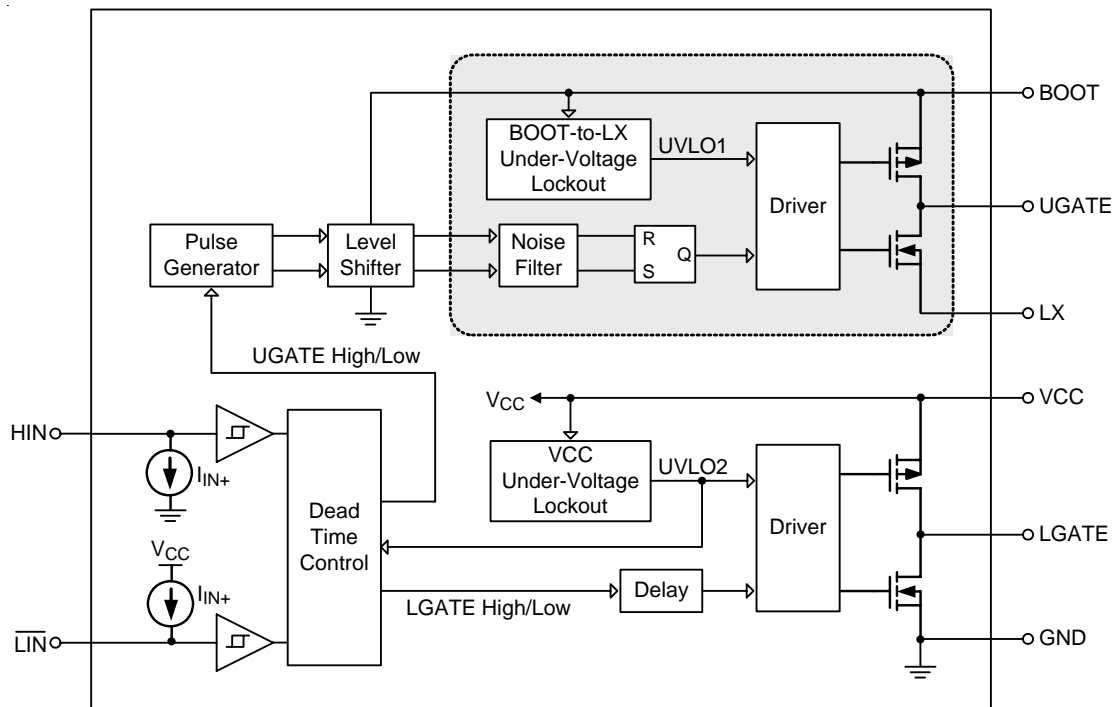

Operation

The RT7020 is a high-voltage gate driver for driving high-side and low-side MOSFETs in a half-bridge configuration. The RT7020 uses ultra high voltage device and floating well to allow UGATE to drive external MOSFET operating up to 600V. When the HIN voltage is above the logic-high threshold, the UGATE voltage goes to turn on the external MOSFET. When the HIN voltage is below the logic-low threshold, the MOSFET is turned off.

The operating behavior of the LGATE, controlled by the LIN pin, is like the behavior of the UGATE.

Under-Voltage Lockout (UVLO) Function

When the VCC or BOOT-to-LX voltage is lower than the UVLO threshold, the UGATE and LGATE output will be disabled.

Pulse Generator

The pulse generator is used to transmit the HIN input signal to the UGATE driver.

Dead-Time Control

The dead-time control function is designed to prevent the high-side and low-side MOSFETs from shoot-through.

## Absolute Maximum Ratings (Note 1)

- VCC Supply Voltage,  $V_{CC}$  ----- -0.3 to 25V
- LX to GND ----- -0.3V to 625V
- BOOT to LX,  $V_{BOOT-LX}$  ----- -0.3V to 25V
- UGATE to LX ----- -0.3V to  $V_{BOOT-LX} + 0.3V$
- LGATE to GND ----- -0.3V to  $V_{CC} + 0.3V$
- HIN,  $\overline{LIN}$  to GND ----- -0.3V to  $V_{CC} + 0.3V$
- Allowable LX Voltage Slew Rate,  $dV_{LX}/dt$  ----- -50V/ns to 50V/ns
- Power Dissipation,  $P_D$  @  $T_A = 25^\circ C$ 
  - SOP-8 ----- 0.53W
  - DIP-8 ----- 0.74W
- Package Thermal Resistance (Note 2)
  - SOP-8,  $\theta_{JA}$  ----- 188°C/W
  - DIP-8,  $\theta_{JA}$  ----- 134.9°C/W
- Junction Temperature ----- 150°C
- Lead Temperature (Soldering, 10 sec.) ----- 260°C
- Storage Temperature Range ----- -65°C to 150°C

## Recommended Operating Conditions (Note 3)

- VCC Supply Voltage,  $V_{CC}$  ----- 10V to 20V
- BOOT-to-LX,  $V_{BOOT-LX}$  ----- 10V to 20V
- LX to GND ----- 0 to 600V
- UGATE to LX ----- 0 to  $V_{BOOT-LX}$
- LGATE to GND ----- 0 to  $V_{CC}$
- HIN,  $\overline{LIN}$  to GND ----- 0 to  $V_{CC}$
- Junction Temperature Range ----- -40°C to 125°C
- Ambient Temperature Range ----- -40°C to 85°C

## Electrical Characteristics

( $V_{CC} = V_{BOOT-LX} = 15V$ ,  $T_A = 25^\circ C$ , unless otherwise specified)

Parameter	Symbol	Test Conditions	Min	Typ	Max	Unit
VCC Under-Voltage Lockout Threshold (On)	$V_{THON\_VCC}$		9	10.5	12	V
$V_{BOOT-LX}$ Under-Voltage Lockout Threshold (On)	$V_{THON\_BOOT}$		9	10.5	12	V
VCC Under-Voltage Lockout Threshold (Off)	$V_{THOFF\_VCC}$		8	9.5	11	V
$V_{BOOT-LX}$ Under-Voltage Lockout Threshold (Off)	$V_{THOFF\_BOOT}$		8	9.5	11	V
VCC Under-Voltage Lockout Hysteresis	$V_{HYS\_VCC}$		--	1	--	V
$V_{BOOT-LX}$ Under-Voltage Lockout Hysteresis	$V_{HYS\_BOOT}$		--	1	--	V

Parameter		Symbol	Test Conditions	Min	Typ	Max	Unit
LX Leakage Current		$I_{LK}$	$V_{BOOT} = V_{LX} = 600V$	--	--	50	$\mu A$
VCC Quiescent Current		$I_{Q\_VCC}$		--	220	400	$\mu A$
BOOT-to-LX Quiescent Current		$I_{Q\_BOOT-LX}$		--	100	200	$\mu A$
VCC Operating Current		$I_{P\_VCC}$	Frequency = 20kHz, UGATE = LGATE = Open	--	--	600	$\mu A$
BOOT-to-LX Operating Current		$I_{P\_BOOT-LX}$		--	--	600	$\mu A$
HIN, $\overline{LIN}$ Input Voltage	Logic-High	$V_{IH}$		2.5	--	--	V
	Logic-Low	$V_{IL}$		--	--	0.8	
UGATE, LGATE Output Voltage	High-Level	$V_{OH}$	Sinking Current = 2mA, $V_{BOOT} - V_{UGATE}, V_{CC} - V_{LGATE}$	--	50	200	mV
	Low-Level	$V_{OL}$	Sinking Current = 2mA, $V_{UGATE-LX},$ $V_{LGATE}$	--	20	100	
HIN Input Current	Logic-High	$I_{IN+}$	$HIN = V_{CC}, \overline{LIN} = GND$	--	2	10	$\mu A$
	Logic-Low	$I_{IN-}$	$HIN = GND, \overline{LIN} = V_{CC}$	-1	--	--	
UGATE and LGATE Sourcing Current		$I_{O+}$	UGATE = LX, LGATE = GND, Current pulse width < 10 $\mu s$ , Low duty	--	290	--	mA
UGATE and LGATE Sinking Current		$I_{O-}$	UGATE = LX, LGATE = GND, Current pulse width < 10 $\mu s$ , Low duty	--	600	--	

**Dynamic Electrical Characteristics (Note 4)**

( $V_{CC} = V_{BOOT-LX} = 15V, LX = GND, C_L = 1000pF, T_A = 25^\circ C$ , unless otherwise specified)

Parameter	Symbol	Test Conditions	Min	Typ	Max	Unit
Turn-on Delay	$t_{ON}$		--	680	820	ns
Turn-off Delay	$t_{OFF}$	$V_{LX} = 0$ or 600V (Note 5)	--	150	300	ns
Turn-on Rising Time	$t_R$		--	70	170	ns
Turn-off Falling Time	$t_F$		--	35	90	ns
Dead-Time	$t_{Dead}$		--	520	650	ns

**Note 1.** Stresses beyond those listed “Absolute Maximum Ratings” may cause permanent damage to the device. These are stress ratings only, and functional operation of the device at these or any other conditions beyond those indicated in the operational sections of the specifications is not implied. Exposure to absolute maximum rating conditions may affect device reliability.

**Note 2.**  $\theta_{JA}$  is measured at  $T_A = 25^\circ C$  on a high effective thermal conductivity four-layer test board per JEDEC 51-7.

**Note 3.** The device is not guaranteed to function outside its operating conditions.

**Note 4.** Please refer to the Timing Diagram and Dynamic Waveforms in the Application Information.

**Note 5.** Turn-off Delay for  $V_{LX} = 600V$  is guaranteed by design.

## Typical Application Circuit

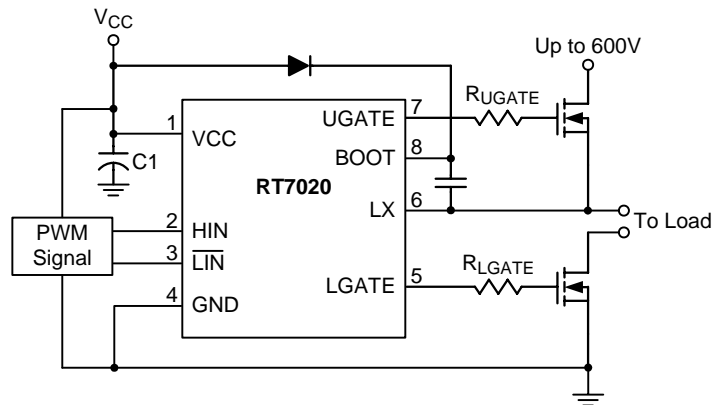

**Typical Operating Characteristics**

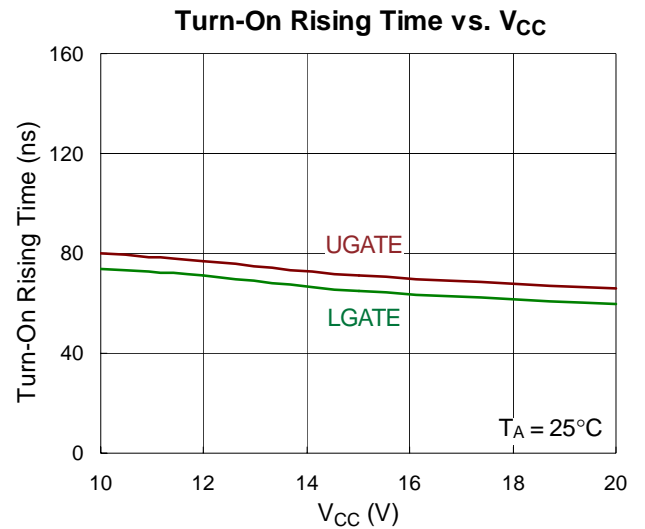
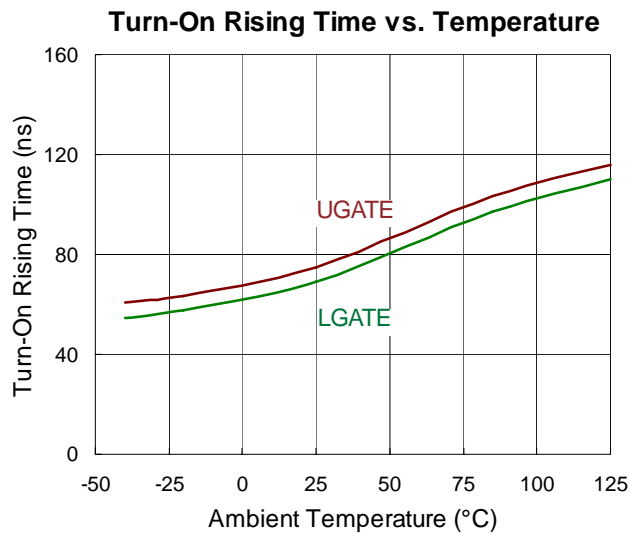
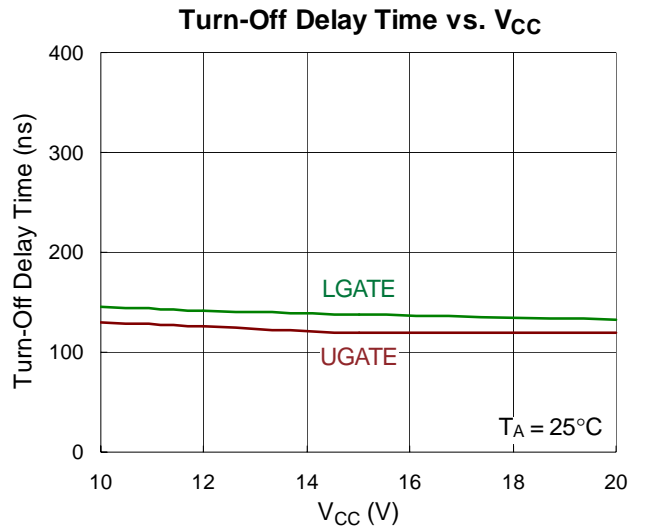
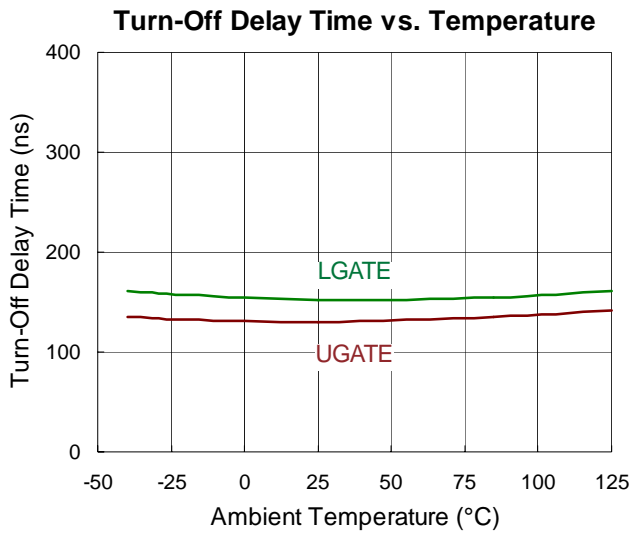
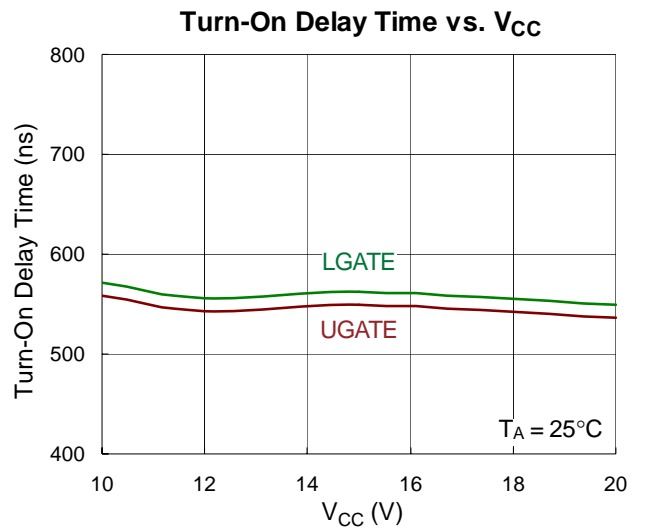
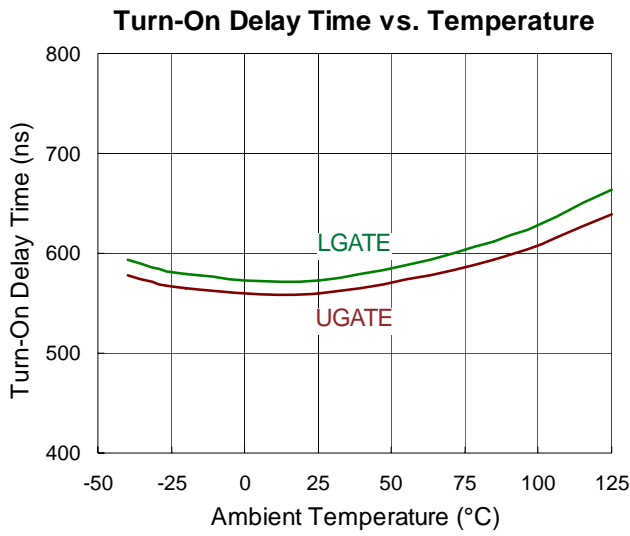

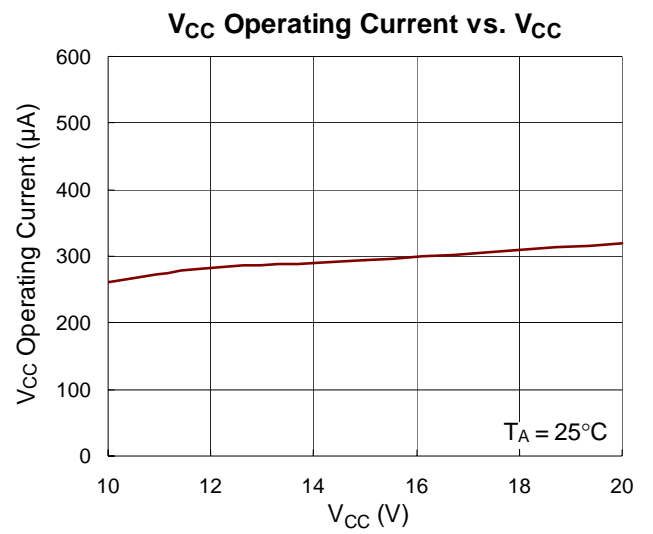
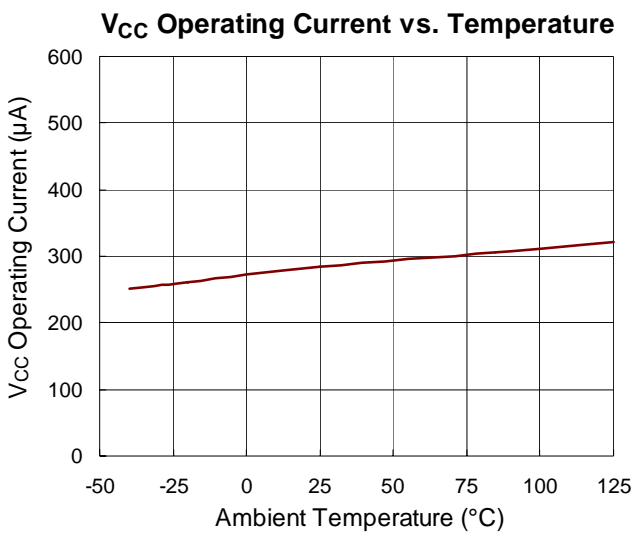
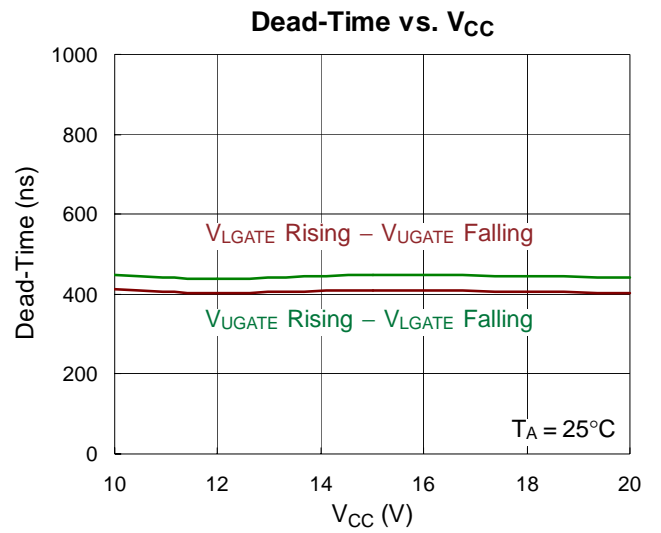
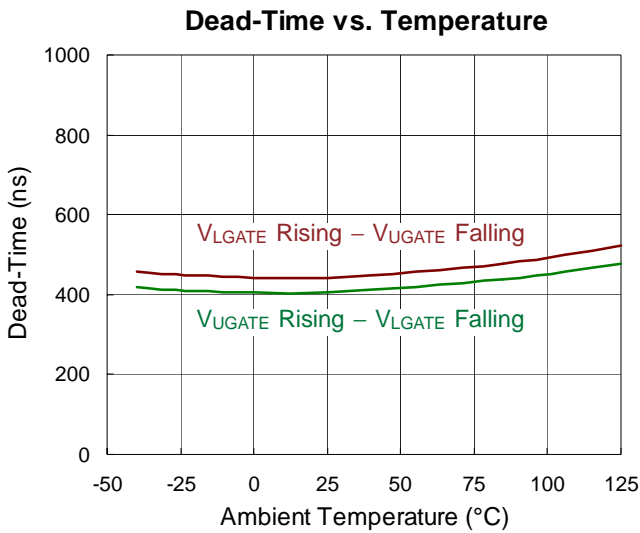
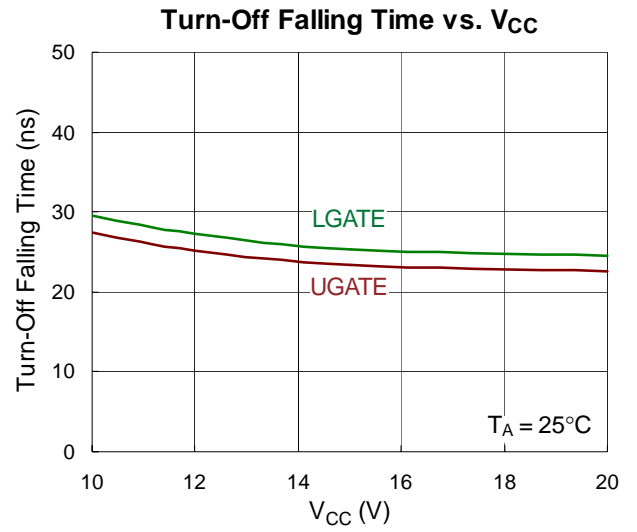
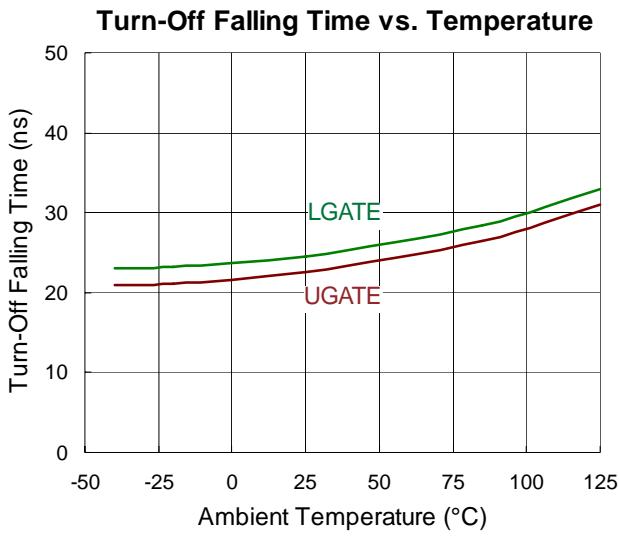



**V<sub>BOOT-LX</sub> Operating Current vs. Temperature**

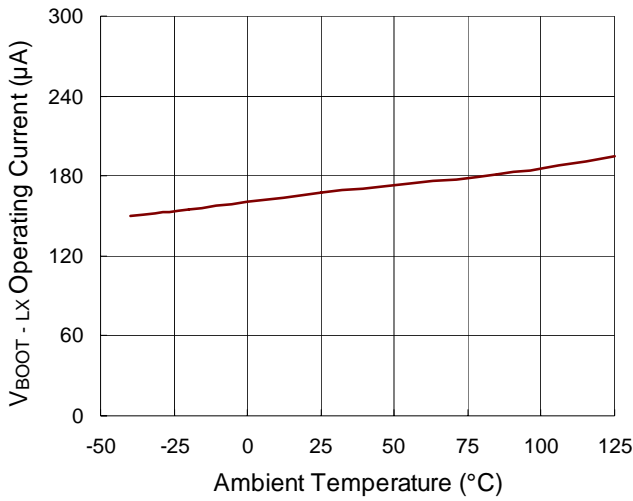

**V<sub>BOOT-LX</sub> Operating Current vs. V<sub>BOOT-LX</sub>**

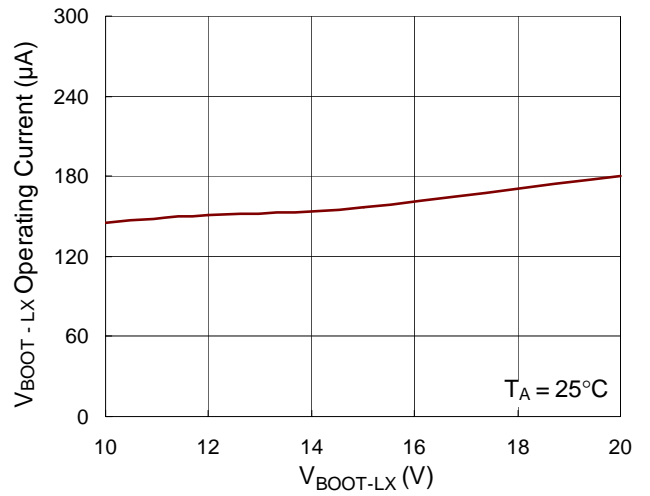

**LX Leakage Current vs. Temperature**

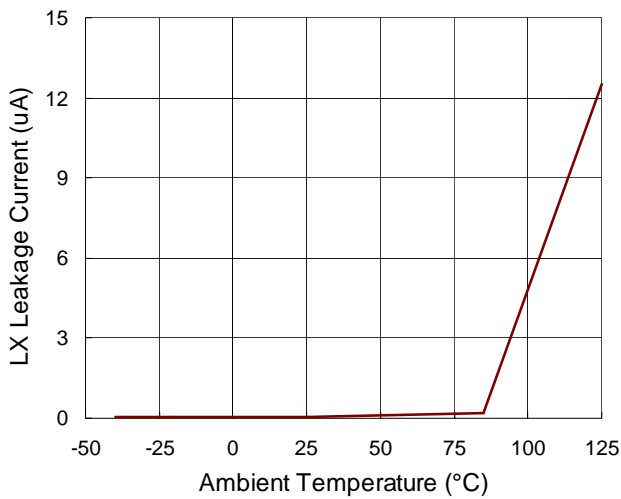

**Logic-High Threshold Voltage vs. Temperature**

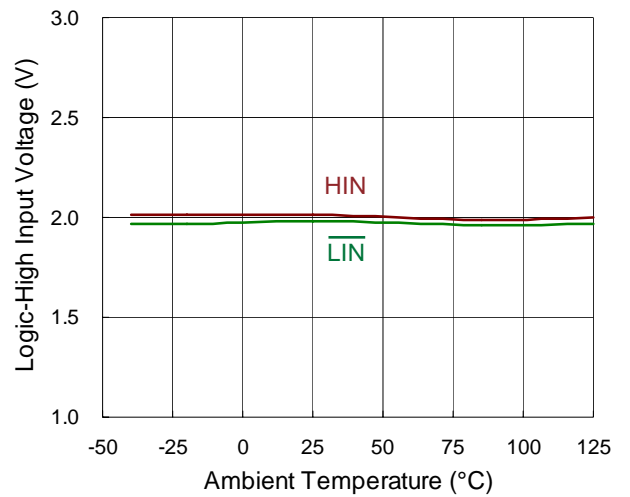

**Logic-High Threshold Voltage vs. V<sub>CC</sub>**

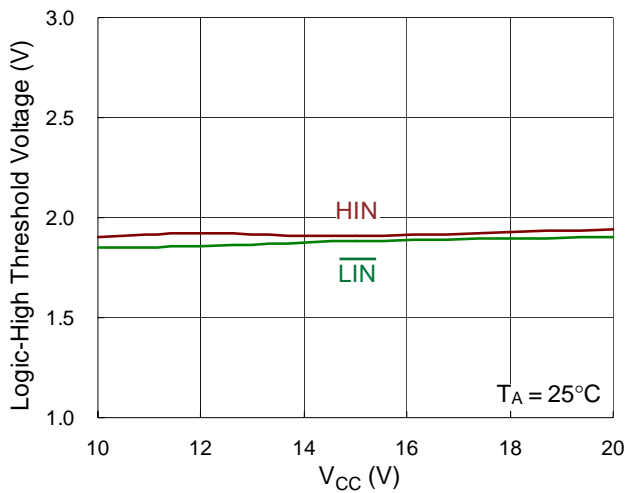

**Logic-Low Threshold Voltage vs. Temperature**

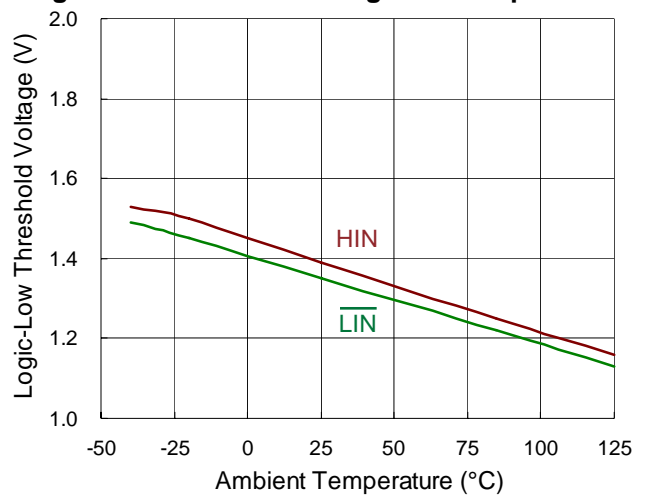

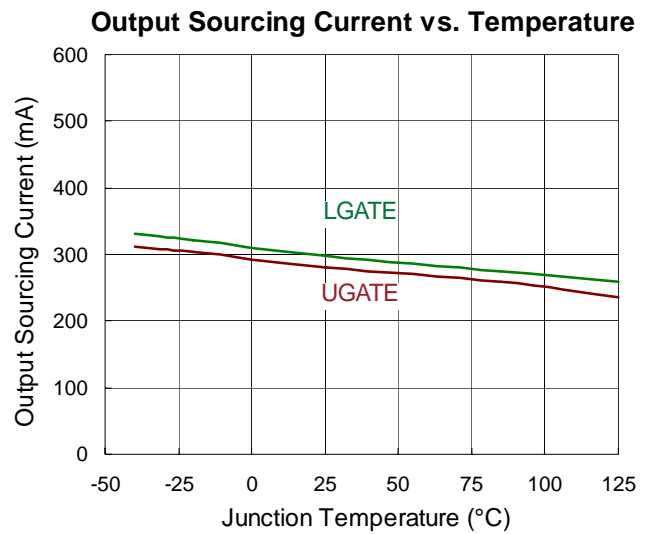
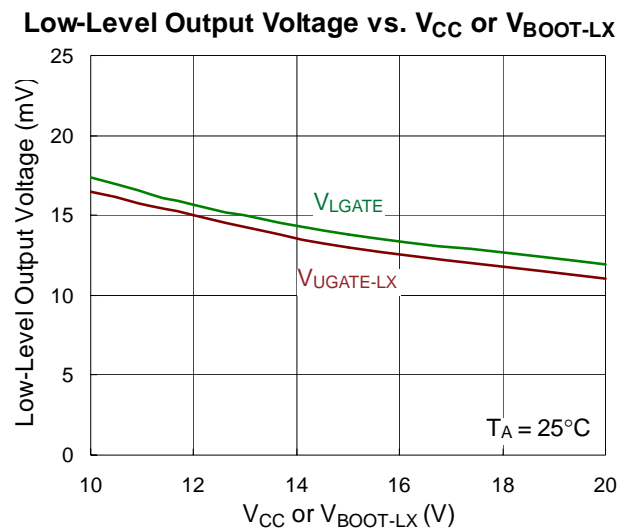
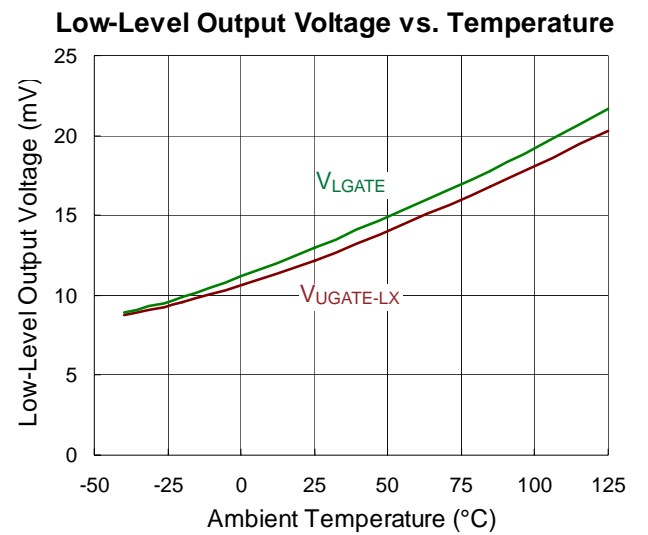
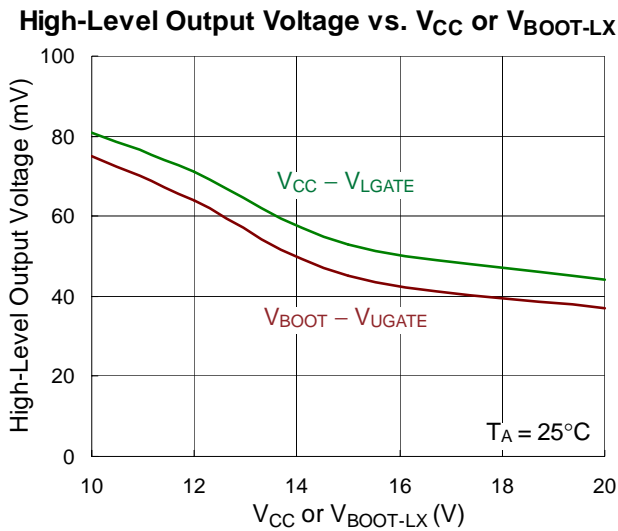
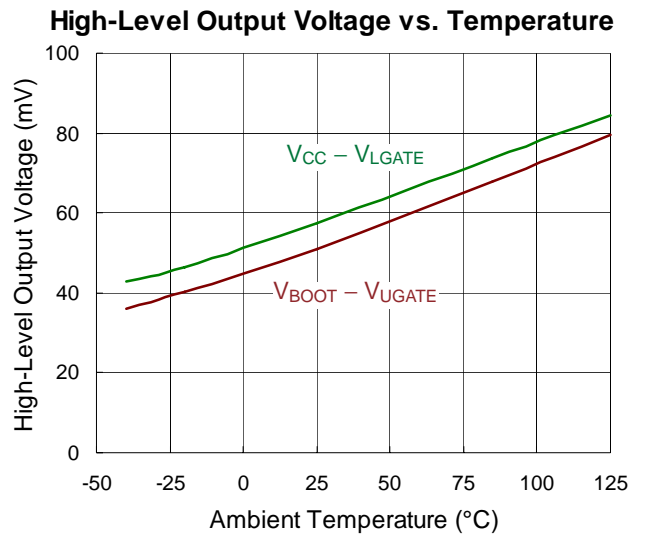
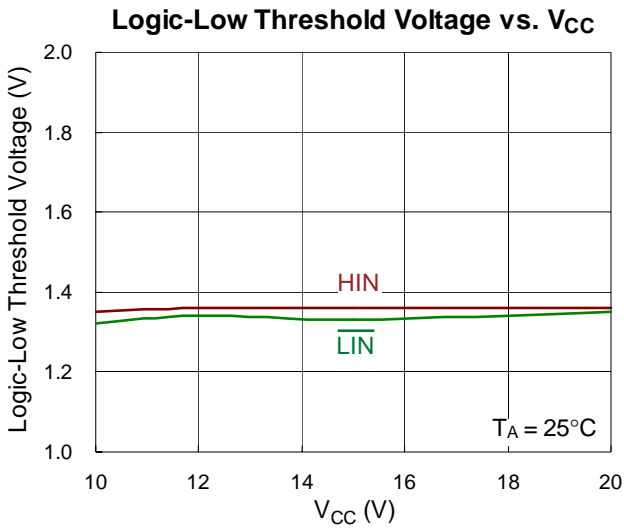

**Output Sourcing Current vs.  $V_{CC}$  or  $V_{BOOT-LX}$**

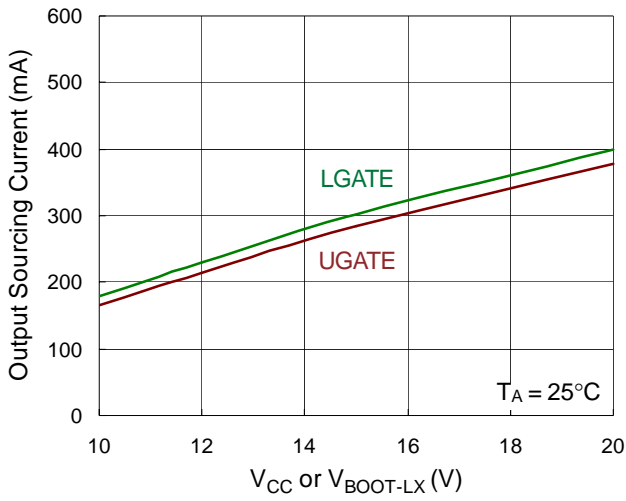

**Output Sinking Current vs. Temperature**

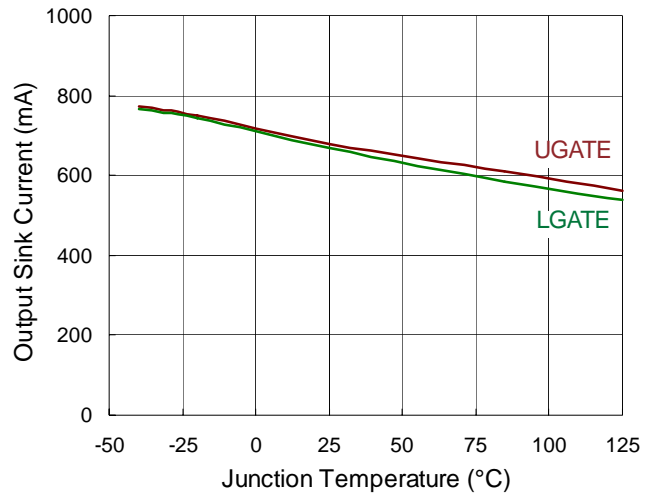

**Output Sinking Current vs.  $V_{CC}$  or  $V_{BOOT-LX}$**

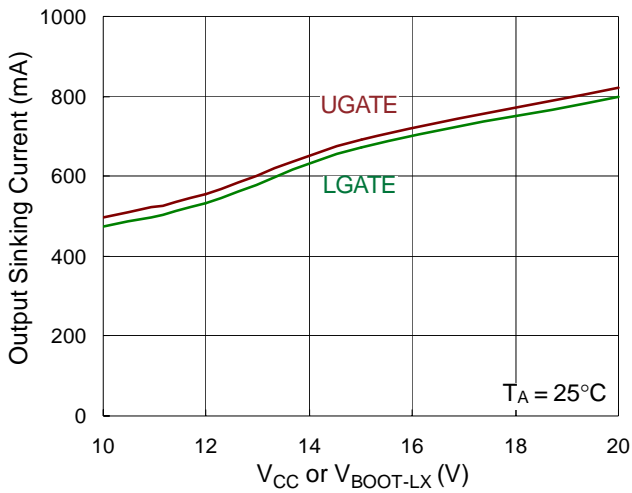

**$V_{THON\_VCC} / V_{THOFF\_VCC}$  vs. Temperature**

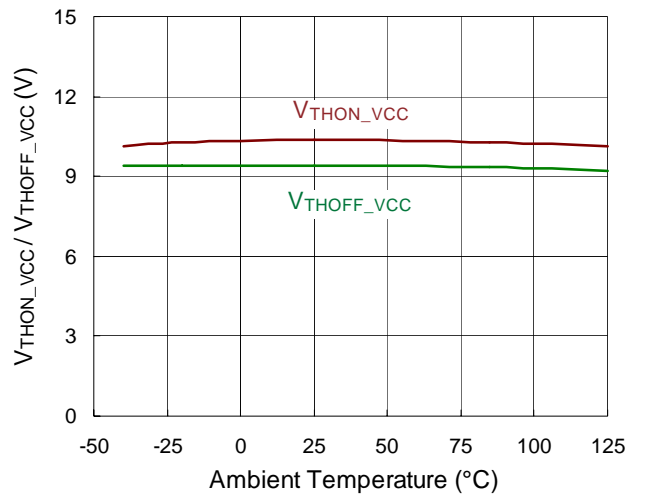

**$V_{THON\_BOOT} / V_{THOFF\_BOOT}$  vs. Temperature**

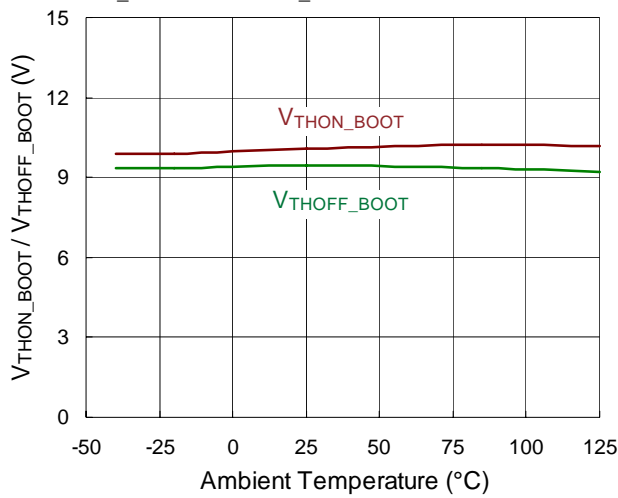

**$V_{HYS\_VCC}$  vs. Temperature**

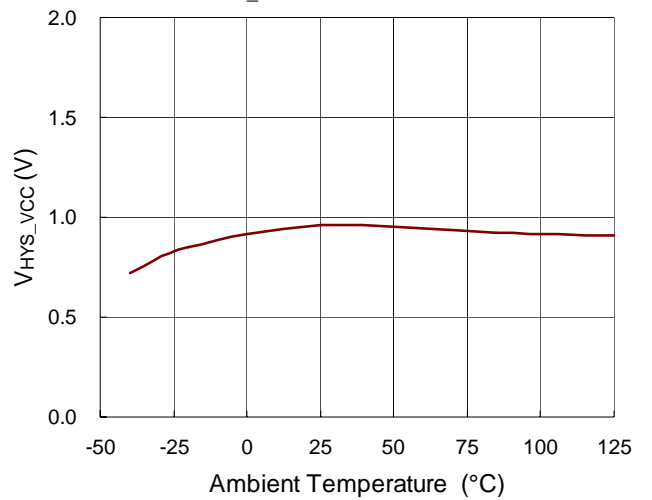

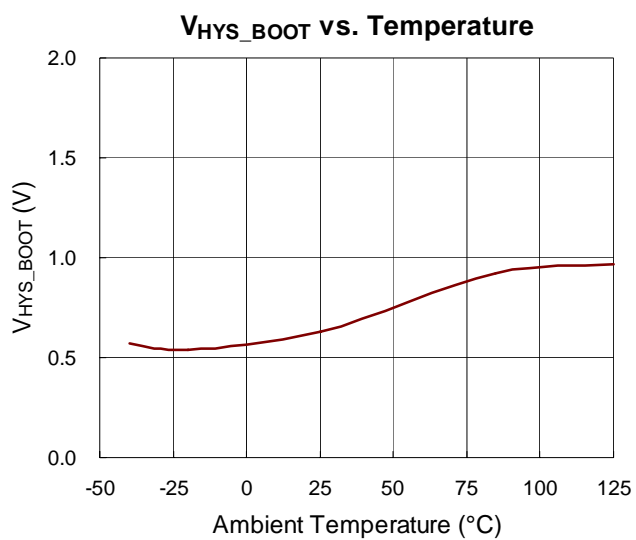

## Application Information

### Timing Diagram and Dynamic Waveforms

Figure 1 is the RT7020 input/output timing diagram, and Figure 2 is a definition of dynamic characteristics. You can know those definitions and the relationship between input and output from these figures. For example :  $t_{ON}$ ,  $t_{OFF}$ ,  $t_R$ ,  $t_F$ ...

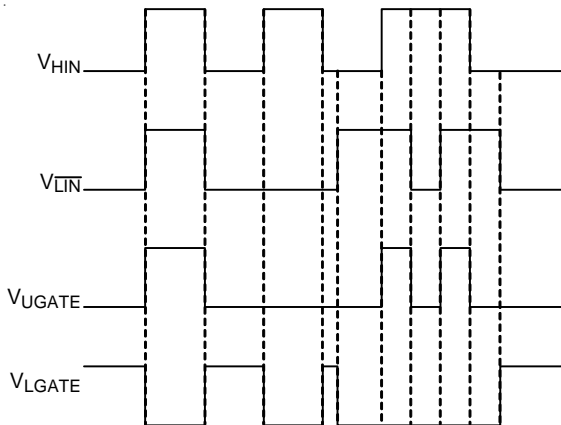

Figure 1. Input/Output Timing Diagram

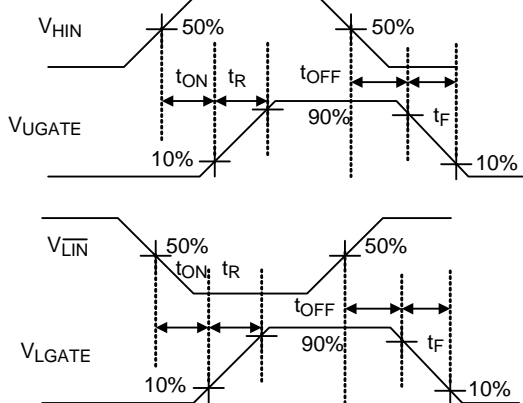

Figure 2. Dynamic Electrical Characteristics Definition

### Deadtime, $t_{Dead}$

To avoid the simultaneous conduction of high-side and low-side power switches cause shoot through, the switching operation of the IC control circuit introduces a deadtime function. In the deadtime period, even if the input sends another power switch conduction signal, the control circuit will remain closed drive state. Figure 3 illustrates the definition of deadtime and the relationship between the high-side and low-side gate signals.

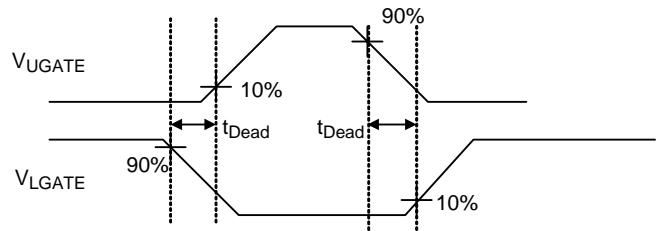

Figure 3. Deadtime Definition

### Matched Propagation Delays between Both Channels

Because the IC internal level shifter circuit causes the propagation delay of the high-side output signal, shown in Figure 4. The RT7020 adds a propagation delay matching circuit in the low-side logic circuit, so that high-side and low-side output signals approximately synchronization.

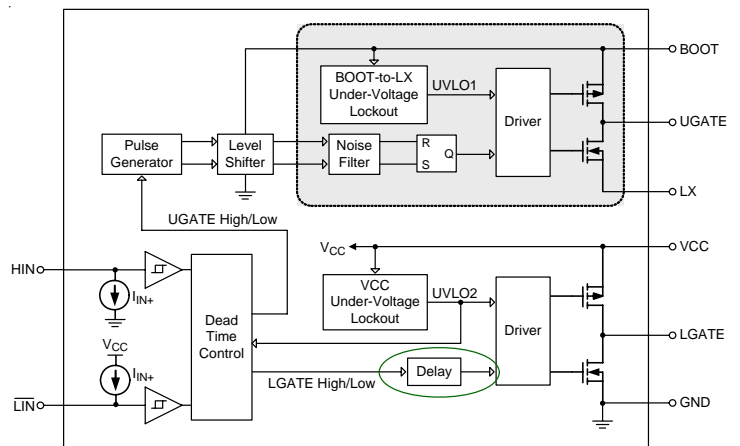

Figure 4. Propagation Delay Matching Circuit

### Thermal Considerations

For continuous operation, do not exceed absolute maximum junction temperature. The maximum power dissipation depends on the thermal resistance of the IC package, PCB layout, rate of surrounding airflow, and difference between junction and ambient temperature. The maximum power dissipation can be calculated by the following formula :

$$P_{D(MAX)} = (T_{J(MAX)} - T_A) / \theta_{JA}$$

where  $T_{J(MAX)}$  is the maximum junction temperature,  $T_A$  is the ambient temperature, and  $\theta_{JA}$  is the junction to ambient thermal resistance.

For recommended operating condition specifications, the maximum junction temperature is 125°C. The junction to ambient thermal resistance,  $\theta_{JA}$ , is layout dependent. For SOP-8 package, the thermal resistance,  $\theta_{JA}$ , is 188°C/W on a standard JEDEC 51-7 four-layer thermal test board. For DIP-8 package, the thermal resistance,  $\theta_{JA}$ , is 134.9°C/W on a standard JEDEC 51-7 four-layer thermal test board. The maximum power dissipation at  $T_A = 25^\circ\text{C}$  can be calculated by the following formula :

$$P_{D(MAX)} = (125^\circ\text{C} - 25^\circ\text{C}) / (188^\circ\text{C/W}) = 0.53\text{W for SOP-8 package}$$

$$P_{D(MAX)} = (125^\circ\text{C} - 25^\circ\text{C}) / (134.9^\circ\text{C/W}) = 0.74\text{W for DIP-8 package}$$

The maximum power dissipation depends on the operating ambient temperature for fixed  $T_{J(MAX)}$  and thermal resistance,  $\theta_{JA}$ . The derating curve in Figure 5 allows the designer to see the effect of rising ambient temperature on the maximum power dissipation.

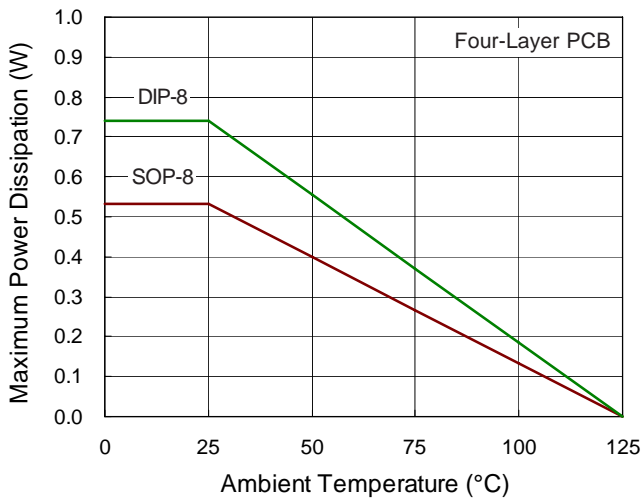

Figure 5. Derating Curve of Maximum Power Dissipation

## Layout Consideration

A proper PCB layout for power supply can reduce unnecessary waveform noise and electromagnetic interference problems to ensure proper system operation, please refer to the following PCB layout considerations:

- ▶ For the high voltage and high current loop layout of power supply should be as thick and short. Avoid excessive layout generated parasitic inductance and resistors to cause significant noise.
- ▶ In order to shorten the length of IC layout, you need to consider the relative placement for IC and the power switches. It is recommended that the power switches placed in a symmetrical manner, and the IC close to high-side and low-side elements.
- ▶ In order to reduce the noise coupling, it is recommended that the ground layout should not be placed under or near the high voltage floating side.
- ▶ The layout between high-side and low-side power switches should be thick and straight, avoiding the formation of long loops. Too long distance will increase the loop area, and electromagnetic interference suppression capabilities would be affected. However, too short distance may cause overheating situation. It is necessary to consider the most appropriate way.
- ▶ Refer to typical application circuit, the VCC capacitor ( $C_1$ ), BOOT to LX capacitor ( $C_{BOOT}$ ), and bootstrap diode ( $D_{BOOT}$ ) need to be placed as close to the IC as possible to minimize parasitic inductance and resistance. The  $C_{BOOT}$  selected range is from 0.1μF to 0.47μF, and the VCC capacitor ( $C_1$ ) is greater than ten times  $C_{BOOT}$ . It is recommended to use fast or ultra fast reverse recovery time bootstrap diode  $D_{BOOT}$ .
- ▶ In Figure 5, the LX pin voltage drop can be improved by adding  $R_{LX}$  ( $R_{LX} = 1$  to 10Ω), because the  $dv/dt$  is affected by  $(R_{LX} + R_{UGATE})$ .

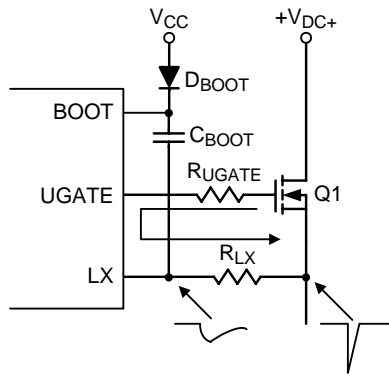

Figure 5. LX Pin Resister

- ▶ If the gate current loop opens circuit for some factors, at this time, the current flows through the gate loop via the power MOSFET drain-to-gate parasitic capacitor. The current will charge the gate-to-source parasitic capacitor to result in power MOSFET wrong action. The power switches can be damaged or burned out, the resistors (about least 10kΩ) are connected between the gate and source pin can prevent malfunction of the power switches.
- ▶ The selection of larger parasitic capacitor power switch or gate resistor may result in too long turn-off time making the high-side and low-side power switches shoot through. In order to prevent the situation, reverse parallel with diodes ( $D_{UGATE}$  &  $D_{LGATE}$ ) in the  $R_{UGATE}$  and  $R_{LGATE}$  (shown in Figure 6), providing a fast discharge path for the power switches in a short time to complete the closing operation.

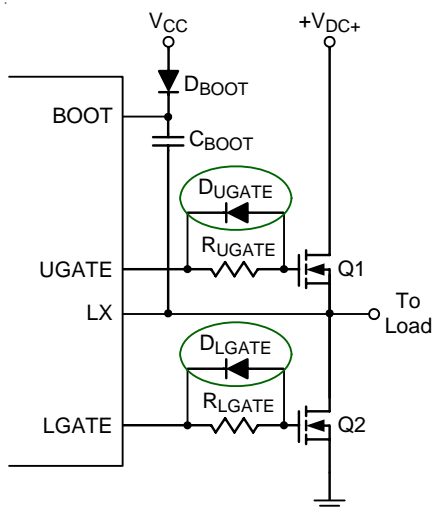
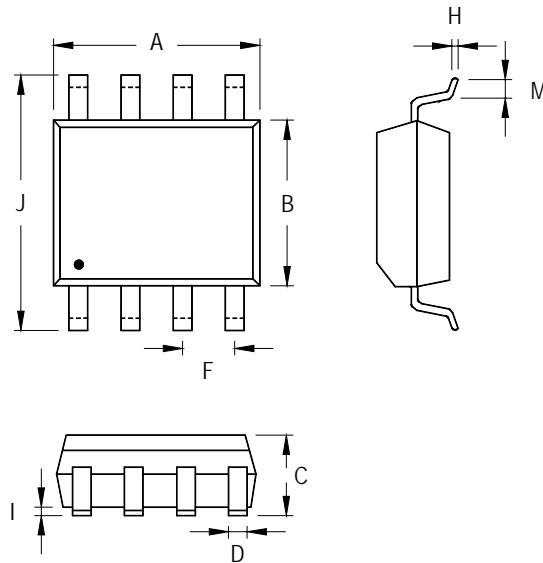

Figure 6. Reverse Parallel with Diodes

Outline Dimension



Symbol	Dimensions In Millimeters		Dimensions In Inches	
	Min	Max	Min	Max
A	4.801	5.004	0.189	0.197
B	3.810	3.988	0.150	0.157
C	1.346	1.753	0.053	0.069
D	0.330	0.508	0.013	0.020
F	1.194	1.346	0.047	0.053
H	0.170	0.254	0.007	0.010
I	0.050	0.254	0.002	0.010
J	5.791	6.200	0.228	0.244
M	0.400	1.270	0.016	0.050

8-Lead SOP Plastic Package



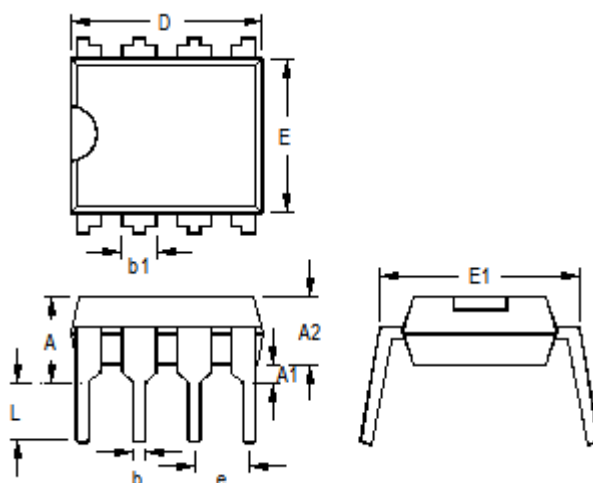

Symbol	Dimensions In Millimeters		Dimensions In Inches	
	Min	Max	Min	Max
A	3.700	4.320	0.146	0.170
A1	0.381	0.710	0.015	0.028
A2	3.200	3.600	0.126	0.142
b	0.360	0.560	0.014	0.022
b1	1.143	1.778	0.045	0.070
D	9.050	9.550	0.356	0.376
E	6.200	6.600	0.244	0.260
E1	7.620	8.255	0.300	0.325
e	2.540		0.100	
L	3.000	3.600	0.118	0.142

**8-Lead DIP Plastic Package**

**Richtek Technology Corporation**

14F, No. 8, Tai Yuen 1<sup>st</sup> Street, Chupei City  
 Hsinchu, Taiwan, R.O.C.  
 Tel: (8863)5526789

Richtek products are sold by description only. Richtek reserves the right to change the circuitry and/or specifications without notice at any time. Customers should obtain the latest relevant information and data sheets before placing orders and should verify that such information is current and complete. Richtek cannot assume responsibility for use of any circuitry other than circuitry entirely embodied in a Richtek product. Information furnished by Richtek is believed to be accurate and reliable. However, no responsibility is assumed by Richtek or its subsidiaries for its use; nor for any infringements of patents or other rights of third parties which may result from its use. No license is granted by implication or otherwise under any patent or patent rights of Richtek or its subsidiaries.