

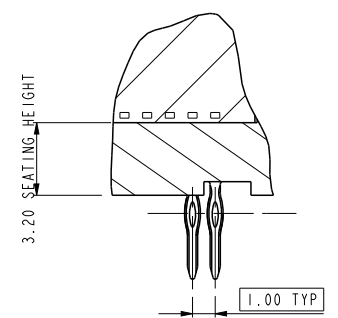

Copyright FCI.

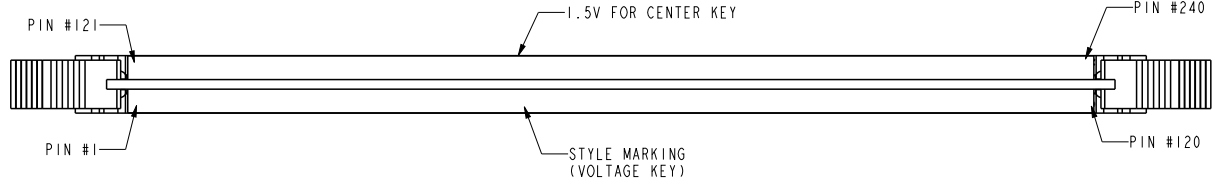

DETAIL A
SCALE 3.000

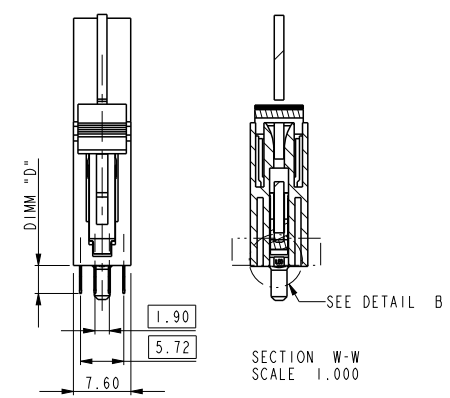
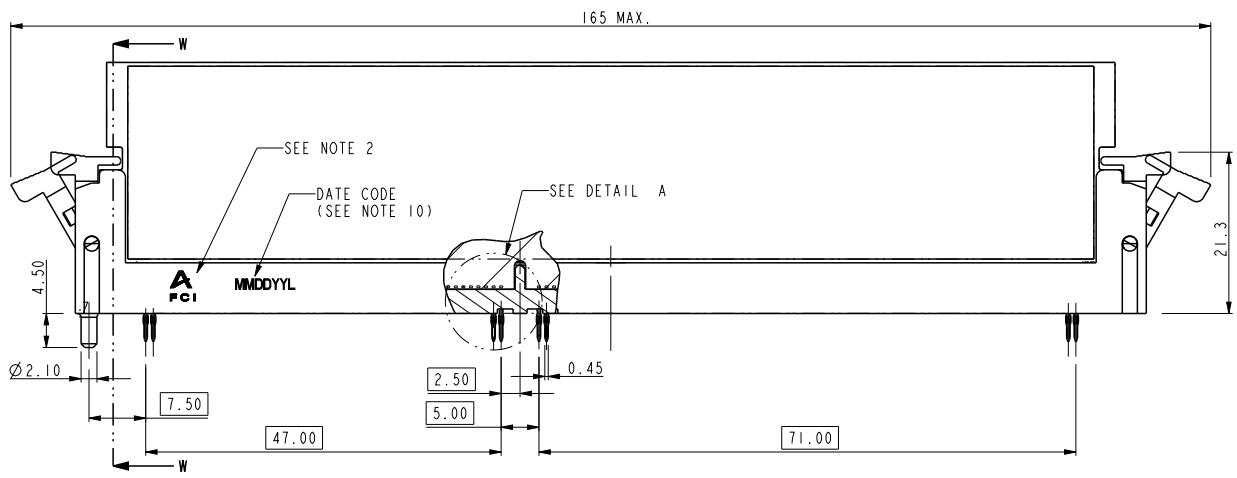

SECTION W-W
SCALE 1.000

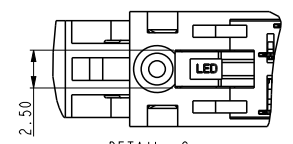
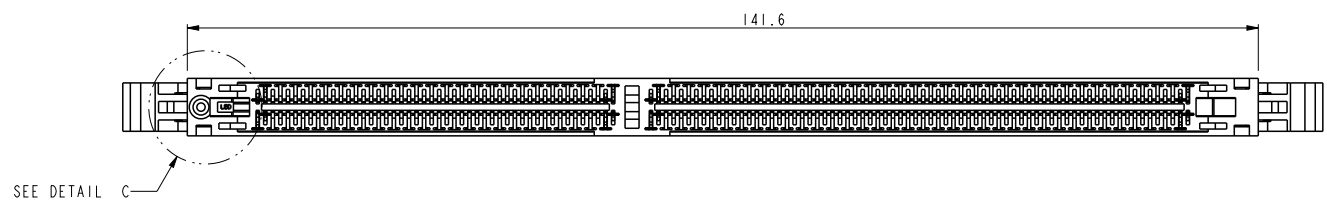

DETAIL C
SCALE 2.000

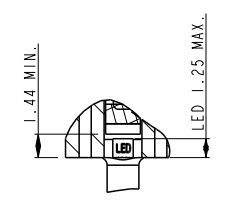

DETAIL B
SCALE 2.000

spec ref	*	dr	Nickor Zuo	2012/03/08	projection 	mm ←→	size	A4	scale	0.500		
tolerance std	TOLERANCES UNLESS OTHERWISE SPECIFIED	eng	Terris Liu	2013/07/23			product family	ecn no	ELX-DG-13787-1			
		chr	Shao-Qi Kuang	2013/07/23				rel level	Released			
surface	✓	appr	Pei-Ming Zheng	2013/07/23	title		DDR III, 240P PRESS-FIT		dwg no	10119101	rev	B
	linear		0.X	±0.38	cat. no.		Product - Customer Drw		sheet 1 of 4			
			0.XX	±0.25								
			0.XXX	±0.13								
	angular		0°	±2°								

ProjE File - REV C - 2009-06-09



Copyright FCI.

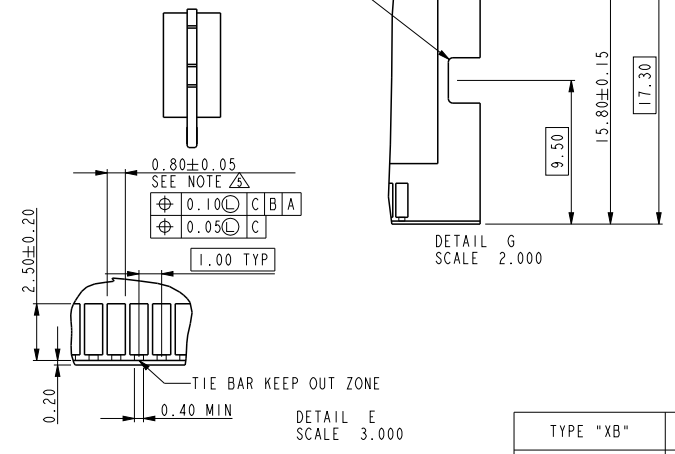
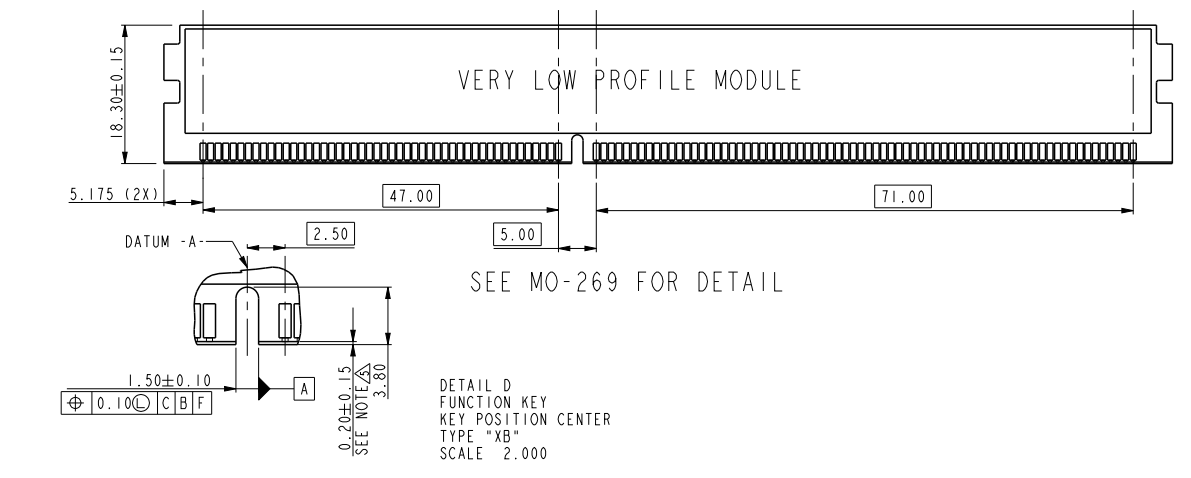
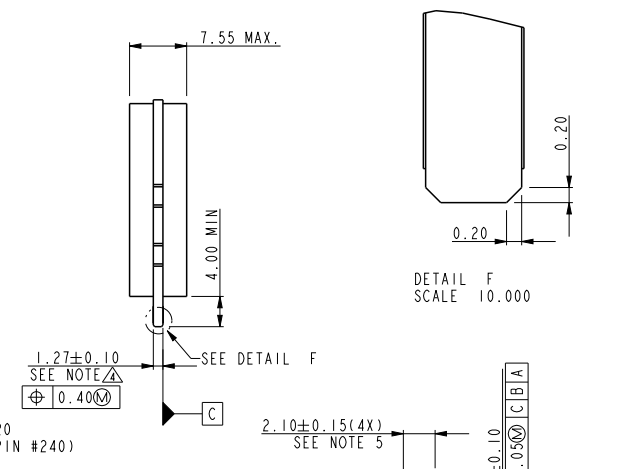
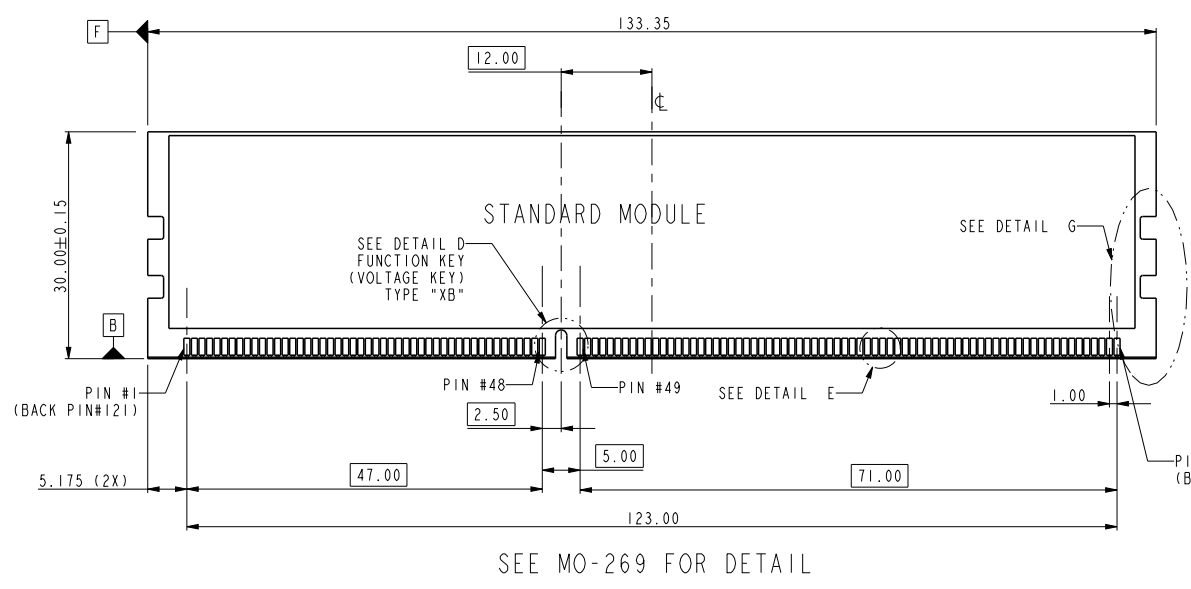

TYPE "XB"	1.5 VOLTAGE
SUB KEY POS #1	DESCRIPTION

spec ref	*	dr	Nickor Zuo	2012/03/08	projection	mm	size	A4	scale	0.500							
tolerance std	TOLERANCES UNLESS OTHERWISE SPECIFIED	eng	Terris Liu	2013/07/23			ecn no	ELX-DG-13787-1									
		chr	Shao-Qi Kuang	2013/07/23				rel level	Released								
		appr	Pei-Ming Zheng	2013/07/23	product family												
surface	<table border="1"> <tr> <td>linear</td> <td>0.X</td> <td>±0.38</td> </tr> <tr> <td></td> <td>0.XX</td> <td>±0.25</td> </tr> <tr> <td></td> <td>0.XXX</td> <td>±0.13</td> </tr> <tr> <td>angular</td> <td>0°</td> <td>±2°</td> </tr> </table>	linear	0.X	±0.38		0.XX	±0.25		0.XXX	±0.13	angular	0°	±2°		title DDR III, 240P PRESS-FIT FOR RDIMM MODULE	dwg no 10119101	rev B
linear	0.X	±0.38															
	0.XX	±0.25															
	0.XXX	±0.13															
angular	0°	±2°															
		www.fci.com	cat. no.	*	Product - Customer Drw			sheet 2 of 4									

PrdE File - REV C - 2009-06-09



Copyright FCI.

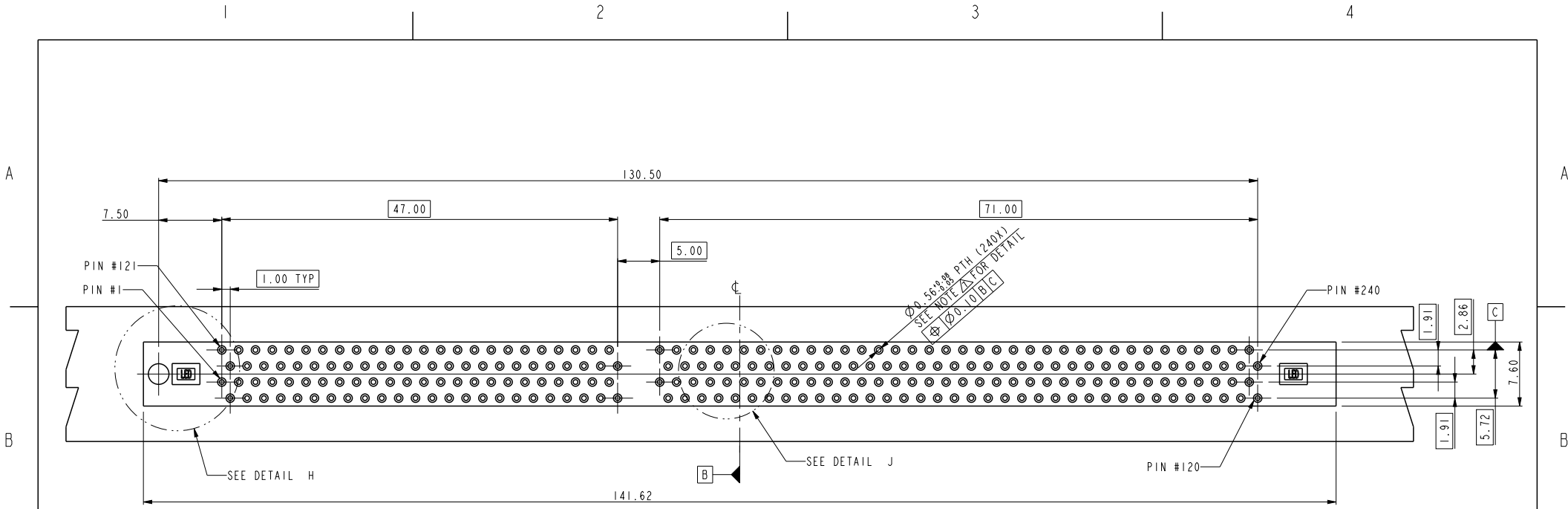

RECOMMENDED CIRCUIT BOARD HOLE LAYOUT

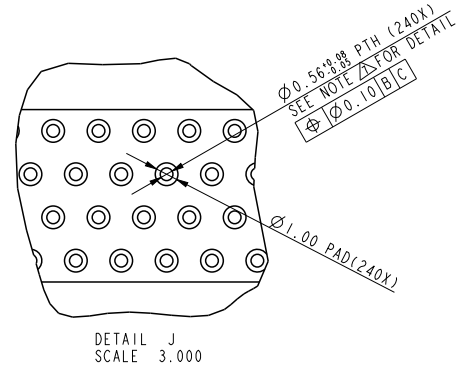
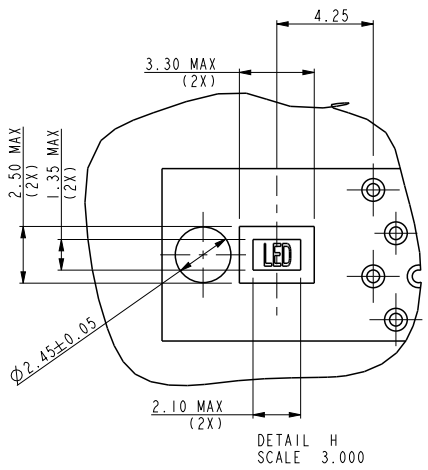

spec ref	*	dr	Nickor Zuo	2012/03/08	projection 	mm 	size	A4	scale	0.500
tolerance std	TOLERANCES UNLESS OTHERWISE SPECIFIED	eng	Terris Liu	2013/07/23			ecn no	ELX-DG-13787-1		
		chr	Shao-Qi Kuang	2013/07/23				rel level	Released	
surface	✓	appr	Pei-Ming Zheng	2013/07/23	product family					
	linear				title	DDR III, 240P PRESS-FIT		dwg no	10119101	
						FOR RDIMM MODULE			rev	
	angular				cat. no.	*	Product - Customer Drw	sheet 3 of 4		B

ProjE File - REV C - 2009-06-09

10119101-□ □ □ □ □ □ □

STYLE: MECHANICAL KEYING
1 : 1.5 VOLT. W/CENTER KEY #1

For RoHS Option:
Blank: Tin-Lead
LF: Lead Free

For Type Option:
Blank: Normal Type
C: Special Type

REVISE
0

PLATING

CODE	DIM. "D"
0	3.30
1	3.70
2	4.20

TAIL LENGTH

CODE	CONTACT	TAIL AREA	UNDERPLATE	CODE	CONTACT	TAIL AREA	UNDERPLATE
2B	15u"(0.38um) MIN. GOLD	35u"~100u" Tin/Lead PLATING	50u"(1.27um) MIN. NICKEL OVERALL	2	15u"(0.38um) MIN. GOLD	35u"~100u" Tin PLATING	50u"(1.27um) MIN. NICKEL OVERALL
3B	30u"(0.76um) MIN. GOLD			3	30u"(0.76um) MIN. GOLD		
4B	3u"(0.076um) MIN. GOLD			4	3u"(0.076um) MIN. GOLD		
6B	15u"(0.38um) MIN. GOLD (LUBRICATED)	35u"~100u" Tin/Lead PLATING	50u"(1.27um) MIN. NICKEL OVERALL	6	15u"(0.38um) MIN. GOLD (lubricated)	35u"~100u" Tin PLATING	50u"(1.27um) MIN. NICKEL OVERALL
7B	30u"(0.76um) MIN. GOLD (LUBRICATED)			7	30u"(0.76um) MIN. GOLD (LUBRICATED)		
8B	3u"(0.076um) MIN. GOLD (LUBRICATED)			8	3u"(0.076um) MIN. GOLD (LUBRICATED)		

COLOR OF HOUSING AN EJECTOR

- 0 : BLACK HOUSING + IVORY EJECTOR
- 1 : BLACK HOUSING + AMBER COLOR EJECTOR
- 2 : BLACK HOUSING + BLACK EJECTOR
- 3 : IVORY HOUSING + IVORY EJECTOR
- 4 : BLUE HOUSING + IVORY EJECTOR

- NOTE:
- MATERIAL:
HOUSING: HIGH PERFORMANCE RESINS, GLASS FILLED UL94V-0 RATED,
EJECTOR: HIGH PERFORMANCE RESINS, GLASS FILLED UL94V-0 RATED,
TERMINAL: COPPER ALLOY.
 - FCI LOGO TO BE APPROXIMATELY LOCATED AS SHOWN ON PRINT.
 - PRODUCT SPECIFICATION: GS-12-617
 - CARD THICKNESS APPLIES ACROSS TABS AND INCLUDES PLATING AND / OR METALIZATION.
 - LEADING EDGE OF CONTACT PADS SPECIFIED BY THE KEEP OUT ZONE SHALL BE FREE OF BURRS AND EXTERNAL TIE BARS.
FOR OPTIMUM PERFORMANCE, THE TIE BAR IS TO BE ON AN INTERNAL LAYER SO THAT THE REMNANT CANNOT CAUSE CONTACT DAMAGE.
 - PACKAGING SPECIFICATION: GS-14-528.
 - ALL PTH SHOULD BE 0.66mm DIA DRILLED AND 0.025mm MIN. ELECTRO-DEPOSITED COPPER THK ON THROUGH HOLE WALL.
 - THIS PRODUCT MEETS EUROPEAN UNION DIRECTIVES AND OTHER COUNTRY REGULATIONS AS DESCRIBED IN GS-22-008.
 - THE AMBER EJECTOR CAN WITHSTAND MAX 174°C EXPOSURE TEMPERATURE
 - DATE CODE MMDDYY IS ASSEMBLY DATE, L IS PRODUCTION LINE("D" DENOTES FCI DONGGUAN).
EXAMPLE: 080311D DENOTES CONNECTOR WAS ASSEMBLED IN AUG. 3RD, 2011, BY DONGGUAN PLANT.



Copyright FCI.

spec ref	*	dr	Nickor Zuo	2012/03/08	projection 	mm 	size	A4	scale	0.500			
tolerance std	TOLERANCES UNLESS OTHERWISE SPECIFIED	eng	Terris Liu	2013/07/23			product family	ecn no	ELX-DG-13787-1				
		chr	Shao-Qi Kuang	2013/07/23				rel level	Released				
		appr	Pei-Ming Zheng	2013/07/23				surface	linear	0.X	±0.38	FCI 	title
0.XX	±0.25	www.fci.com	cat. no.	*	Product - Customer Drw	sheet 4 of 4							
0.XXX	±0.13												
						angular	0°	±2°					